

Rotary blade level indicator
Level limit switch for bulk goods

DF

Operating instructions

Index	Page
Safety instructions	02
Operating instructions	
1. Description	03
2. Installation	04
3. Electrical connection	06
4. Switching logics and function displays	06
5. Setting of the sensitivity	07
6. Use of the measuring blades	07
7. Utilization	08
8. Maintenance and servicing	08
9. Storage	08
10. Disposal	08
Dimensions	09
Measuring blades	10
EU-Declaration of Conformity	11

Congratulation, we felicitate to your good choise.
You have decided for a first class branded product, a rotary blade level indicator from the company MOLLET.

It satisfies highest international standards:

Functionality, versatileness, long service life and design

Thank you for having decided for our product.

- Please, read and follow these safety instructions first and take notice of the operating instructions.

Safety instructions

- 1.1 The installation, initial operation and maintenance may be done by a qualified expert with electrical know-how only.
- 1.2 The connection of the single components as like as measuring blade, anti-buckling protection, shaft extension are permissible only with the attached pins.
- 1.3 For the electrical connection take notice of the local and statutory rules and regulations and/or the VDE 0100.
- 1.4 Before electrical connection, compare the supply voltage with the details at the data plate.
- 1.5 A fuse (with max. 4 A) has to be connected in series to the voltage supply.
- 1.6 Protect the signal contacts from voltage peaks when inductive loads are connected.
- 1.7 The device may put into operation with intact cap-sealing and if it is closed, only.
- 1.8 Switch off the power supply, before opening the device (touchdangerous voltage).



Cable entry

- 2.1 The level indicator will be delivered with a cable gland M20x1.5.
- 2.2 The second drill-hole is closed with a plug screw M20x1.5.
Optional a further cable gland can be delivered.
- 2.3 The cable gland and the plug screw were screwed on at the factory.
Please check if the cable gland or the plug screw were loose during the mounting or the transportation. If so, tighten it again.
- 2.4 The cable gland will be delivered with a PE sealing disc. With it, the level indicator is protected against dust and dirt entry during transportation and storage.
When the indicator is brought into the dusty area it has to be installed immediately at its destine place, the PE sealing disc has to be removed, a cable has to be pulled into the cable gland and the pressure screw has to be screwed on to maintain the type of protection.

ATTENTION

Excessive screw on may injure the type of protection



By use in explosive hazardous areas read and follow the

special conditions and instructions for safe applicate

of the

explosive protection information

first and take notice of the operating instructions.

Operating instructions

1. Description

1.1 Intended use

The electromechanical level limit switch is monitoring the filling level of bulk goods in silos, bunkers, containers, hoppers, weighers, etc..

1.2 Construction

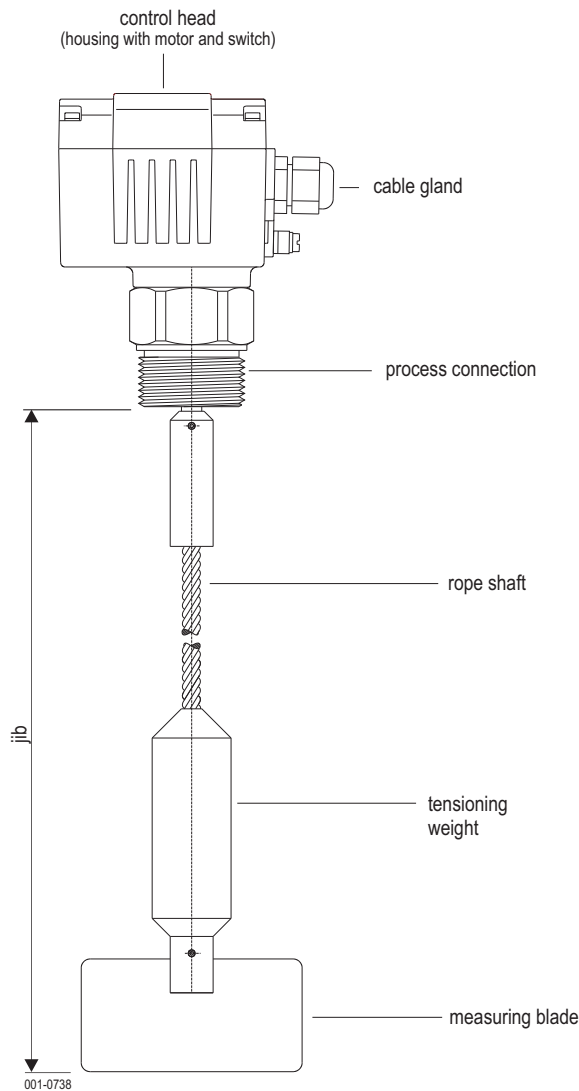

1.3 Function

The rotating measuring blade, projecting into the silo or container, is driven by a gearmotor.

If the bulk material is reaching the measuring blade, the rotation will be hindered and it will be stopped.

The return torque turns the pivoted motor from its end position and actuates the signal switch.

A second switch turns the motor off.

If the filling level of the bulk material sinks, the blade becomes freely again and a spring will turn back the motor into its original end position.

Thereby the motor will be turned on again and the signal switch will be switched back.

1.4 Technical data

Manufacturer	MOLLET Füllstandtechnik GmbH
Address	Industriepark RIO 103 74706 Osterburken
Name	rotary blade level indicator
Type	DF
Bulk goods temperature	T_s see data plate
Ambient temperature	T_a -20 °C ... +70 °C
Pressure range	p see data plate
Measuring blade speed	1 U/min
Response delay	approx. 1.20 sec.
Maintenance	none

1.5 Electrical data

Supply voltage	see data plate
Power consumption	Supply AC 4 VA DC 4 W
Cable entry	cable gland M20 x 1.5
Type of protection	IP IP 66 acc. to DIN 60529
Connection clamps	max. 1.5 mm ²
Signal contact	Contact change-over contact potentialfree
Switching voltage	4 V DC ... 250 V AC
Capacity of the contact	1mA ... 2A

The signal contact is a multivoltage and multicurrent switch. It is suitable for use in circuits with low currents and low voltages as well as for medium currents with control voltages up to 250 V ~AC.

Caution!

During the whole working life, the switch may be used in the same kind of circuit types, only. When the switch has been used once with medium switching capacity, it cannot be used any more for the low switching capacity.

1.6 Materials

Housing	aluminium or stainless steel 1.4401
Process connection	aluminium or stainless steel 1.4301
Rope shaft	stainless steel 1.4301
Tensioning weight	stainless steel 1.4301
Measuring blade	stainless steel 1.4301
Sealing ring (order code)	R0 NBR, black R1 Viton/Teflon/VA R2 NBR, white, FDA conform R5 Teflon

2. Installation

2.1 Preparation

- Read and follow the safety instructions and the operating instructions before mounting the device!
- Inspect if the delivery is complete.
The delivery volume is different, depending on the options.

2.2 Mounting

Thread connection

Put the level indicator together with the sealing at the provided position in the silo or container wall and screw it tightly by means of appropriate tools.

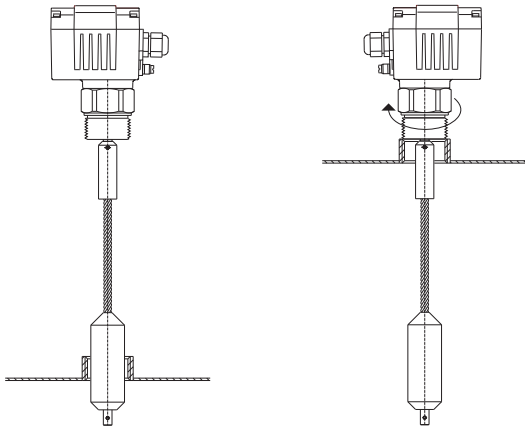

Flange connection

Put the level indicator together with the sealing at the container and fix the flange by means of suitable screws.

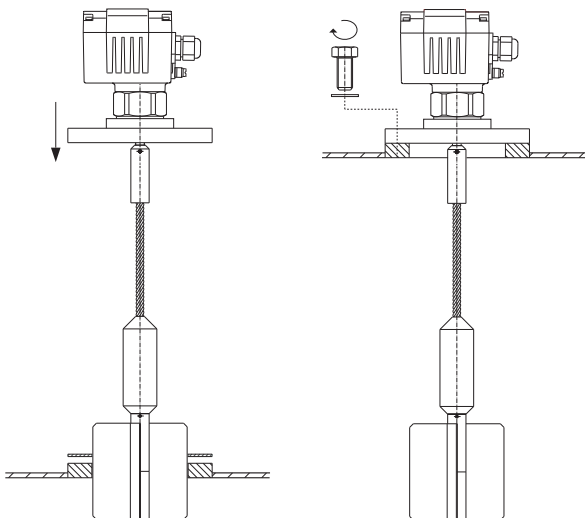

Hinged blade

While installation with a hinged blade, please press both parts of the blade together and insert them through the connection socket.

In the container, the blade is unfolding itself.

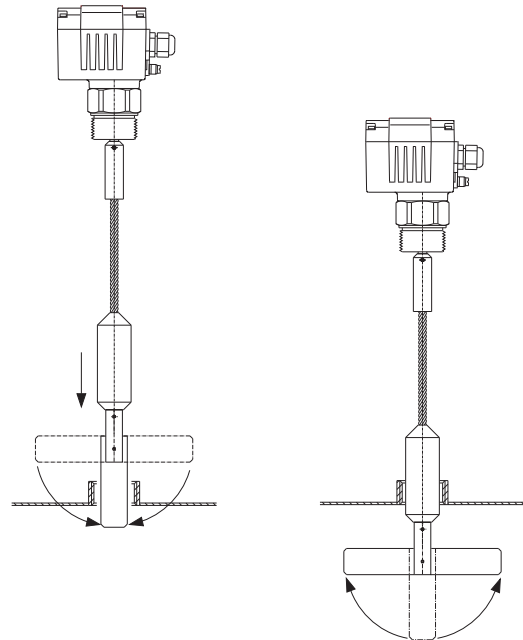

Attention!

The level indicator has to be installed in this way that the jib won't be hit by the filling stream of incoming bulk goods.

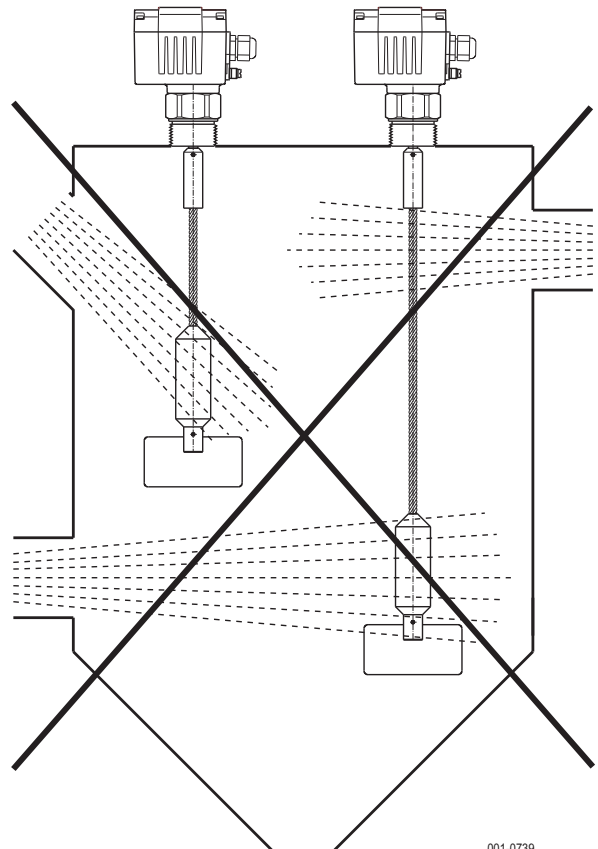

001-0739

2.3 Mounting of the measuring blades

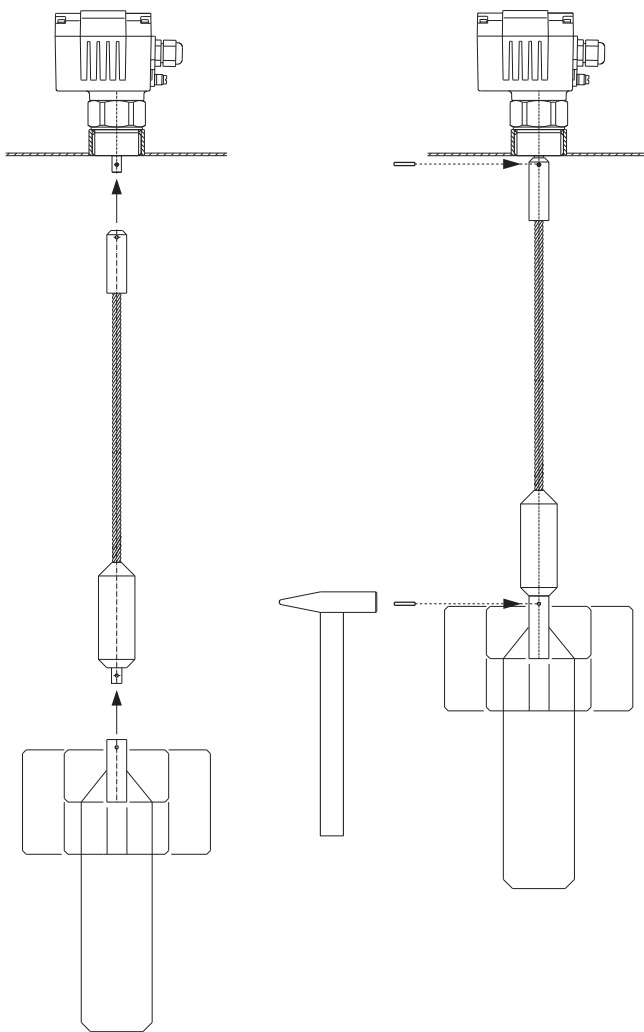

Attention!

During beating the pin into the shaft, you have to support the shaft with an adequate counterpart.

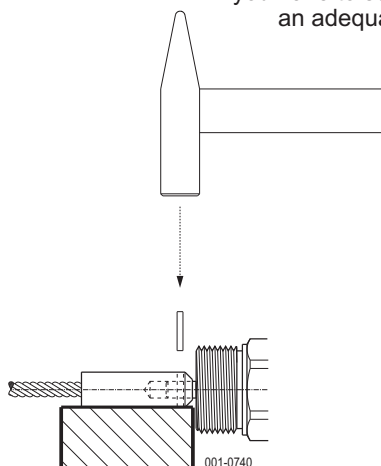

2.4 Orientation of the housing

After mounting, the housing has to be orientated by turning in such a way, that the cable gland is directed towards the cable duct.

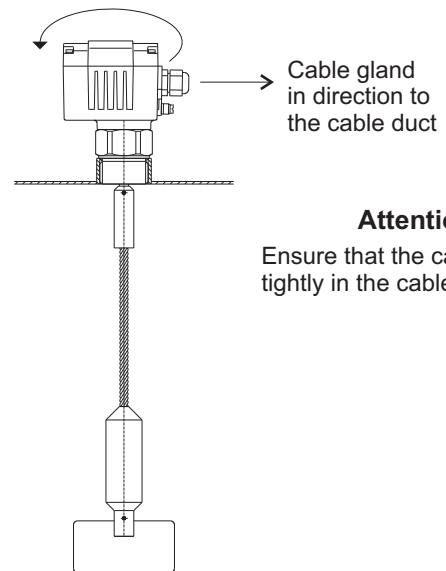

Attention!

Ensure that the cable is fixed tightly in the cable gland.

3. Electrical connection

- Install the wiring and electrical connection in compliance with the circuit diagrams.
- Run the cable between housing and cable protection, in order that the switches and the motor will not be hampered at their necessary movement.
- After the electrical connection the cap nut of the cable gland has to be screwed and please ensure that the cable is fixed strongly and tightly in the cable screwing.

3.1 Circuit diagram AC

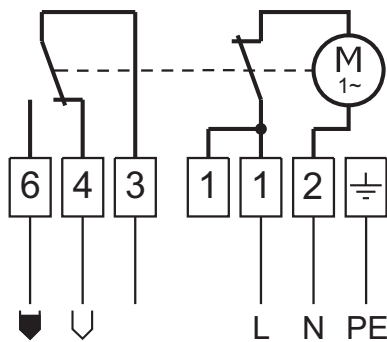

001-AP00

3.2 Circuit diagram DC

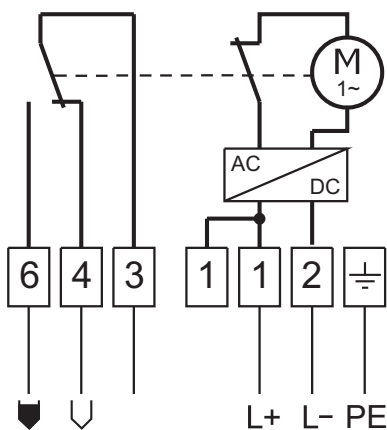

001-AP02

Attention!

Wiring of the level indicator in a way that no undesirable switching function can occur in case of mains voltage failure.

4. Switching logics and function displays

Symbol signification

- = under voltage
- = LED "OFF"
- ◡ = full
- ☀ = LED "ON"
- ∪ = empty

Arrangement and colours of the LEDs for function display

- yellow ○ ● ● ◡ green
- ∪ green

Switching logics

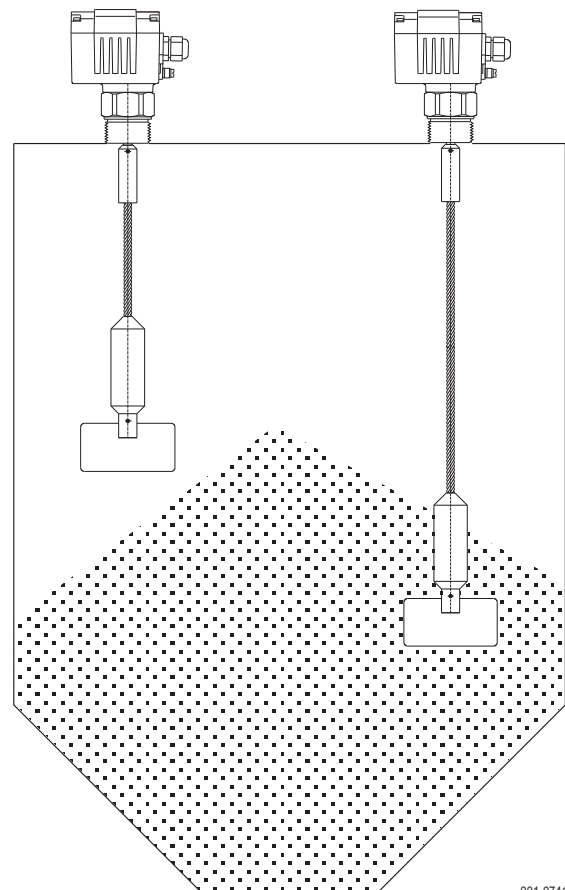
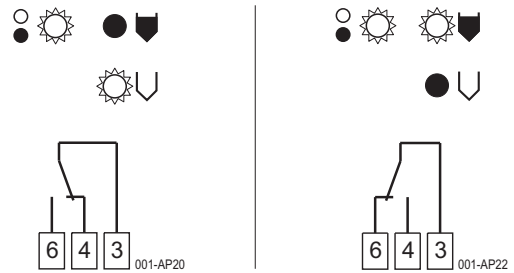

001-0741

5. Setting of the sensitivity

As occasion demands, the sensitivity of the level indicator can be adjusted, referring to the characteristics of the bulk goods, by shifting the spring arm.

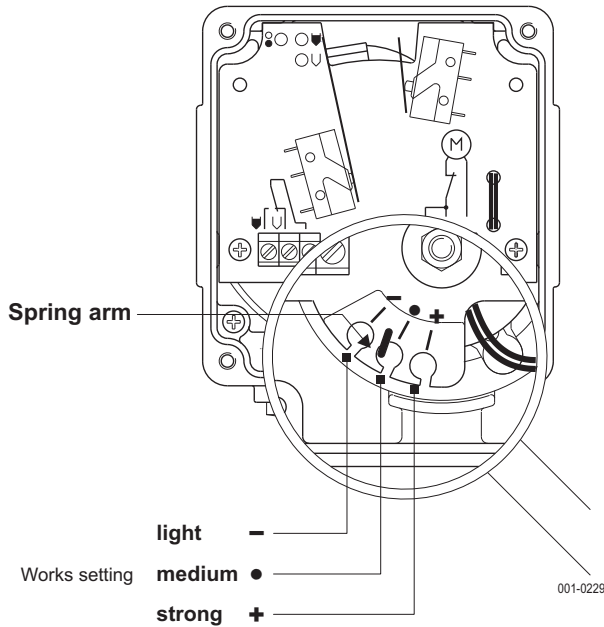

Three settings are possible:

1. **light** for very light bulk goods
2. **medium** suitable for almost all bulk goods
3. **strong** for sticking bulk goods

Fluidised bulk goods are lighter during filling and draining process. This has to be taken appropriately into consideration when setting the spring force and selecting the size of the measuring blade.

6. Use of the measuring blades

Lowest bulk density, the measuring blades can be used for.

Filling level up to 100mm above measuring blade	Bulk density ρ_{SS} in	
	kg/l	t/m ³
Filling level until measuring blade is compl. covered	t/m ³	kg/l

Measuring blade	Blade size	Spring force setting	
		light	medium
S1 Socket blade	100x30	$\frac{0,25}{0,4}$	$\frac{0,35}{0,6}$
S2 Socket blade	130x30	$\frac{0,2}{0,35}$	$\frac{0,3}{0,5}$
M1 Socket blade	90x28	$\frac{0,15}{0,3}$	$\frac{0,2}{0,5}$
M2 Socket blade	90x40	$\frac{0,1}{0,2}$	$\frac{0,15}{0,3}$
T0 Blade T200	68x220	$\frac{0,15}{0,3}$	$\frac{0,25}{0,5}$
T1 Blade T50	98x50	$\frac{0,15}{0,3}$	$\frac{0,25}{0,5}$
T2 Blade T100	98x100	$\frac{0,1}{0,2}$	$\frac{0,2}{0,45}$
T5 Blade T250	250x100	$\frac{0,015}{0,02}$	$\frac{0,02}{0,03}$
T8 Rubber blade	250x100	$\frac{0,015}{0,02}$	$\frac{0,02}{0,03}$
X1 Blade X50	98x50	$\frac{0,15}{0,3}$	$\frac{0,25}{0,5}$
X2 Blade X100	98x100	$\frac{0,1}{0,2}$	$\frac{0,2}{0,45}$
X3 Blade X200	180x100	$\frac{0,025}{0,05}$	$\frac{0,075}{0,15}$
XM Blade X40	44x50	$\frac{0,25}{0,4}$	$\frac{0,35}{0,6}$
K1 Hinged blade T230	200x30	$\frac{0,05}{0,08}$	$\frac{0,07}{0,12}$
SG Blade	126x8	$\frac{0,45}{0,55}$	$\frac{0,65}{0,75}$
TG Blade	98x8	$\frac{0,5}{0,6}$	$\frac{0,7}{0,8}$

7. Utilization

7.1 Putting into operation

- Commissioning of the rotary blade level indicator only, if the installation will be done correctly and if it will be fixed tightly with the electrical contact.
- During operation, the housing and the cable entry must be closed tightly.

7.2 Normal operation

- Use the rotary blade level indicator in its intended application only.
- Operate the level indicator within the intended temperature ranges for the ambient and bulk goods temperature.
- Protect the inside of the control head from soiling.
- When the indicator has to be damaged, you have to take the device out of operation immediately.

7.3 Inexpert handling

- Ignoring of the safety instructions and the operating instructions.
- Utilization of the rotary blade level indicator in not intended use.
- Mounting of spare parts which are no original parts.
- Remove, adding or change of assembling parts, unless this has been described in the documents of the manufacturer.
- Violation against applicable law and standards.

8. Maintenance and servicing

8.1 Maintenance

- In case of intended use, the rotary blade level indicator needs no maintenance.
- Remove deposits and stickings from the blades or wrinkles with a brush or with a scraper. Don't use any force and don't damage the sealing of the shaft.
- Inspect the assemblings inside of the container about signs of wear and tear, in regular intervals. Define the intervals of the control, depending on the bulk goods characteristics.

8.2 Servicing

- Damaged parts, contacts or connections have to be repaired immediately or being replaced with parts of the same kind.
- Until the complete restoration of the proper function, the rotary blade level indicator must not be used any more.

9. Storage

- While storage, the level indicator has to be protected from dust and humidity.
- Please ensure that the shaft of level indicators with jib extension will not be buckled or bended.

10. Disposal

- The level indicator can be recycled.
 - The disposal applies to the valid environmental guidelines according to the location of the carrier and the local manufacturing conditions.
-

Dimensions

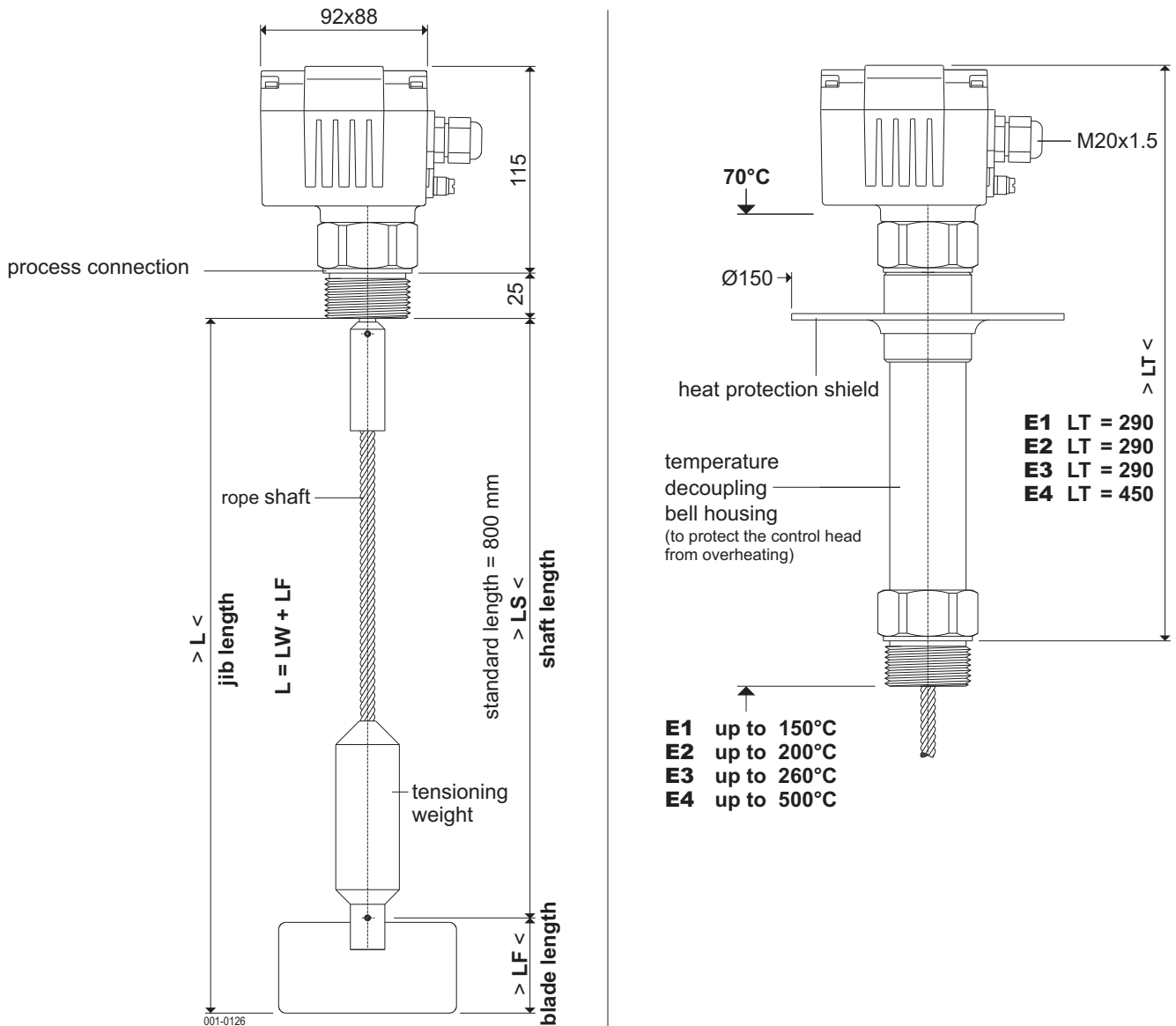

Application instructions

Mounting position	vertical
max. permissible traction force	F_1 max. 4 kN
with reinforced axial bearing (option Z3)	F_1 max. 50 kN

Rope shortening

You can short the rope individually when demanded.

- Open the attachment screws at the tensioning weight and pull the tensioning weight off the rope.
- A tape has to be wrapped round the desired cutting position of the rope, to protect the wire from branching wire pieces.
- Wear goggles while cutting the rope with a cable scissors or an angular grinding machine.
- Remove the tape and mount the tensioning weight at the end of the rope.

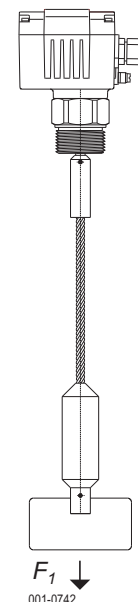

Measuring blades - dimensions

T0 Blade

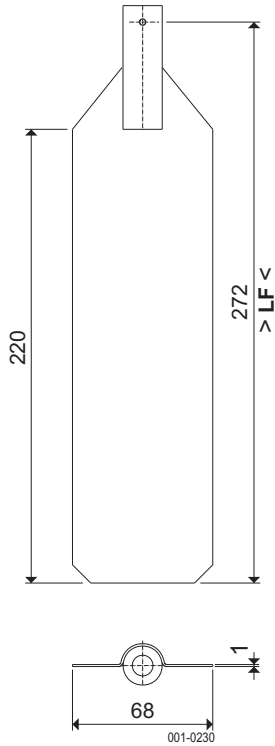

T Blade

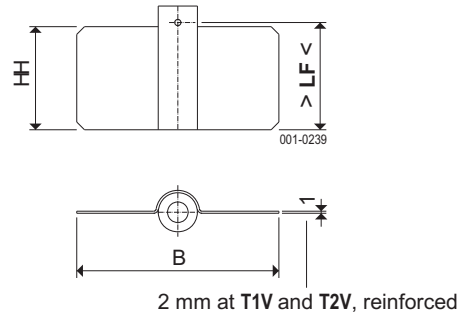

	B	H	LF
T1	98	50	52
T2	98	100	102
T3	200	100	102
T5	250	100	102
T8 ¹⁾	250	100	102

¹⁾ Blades 10 mm thick
in rubber NBR, black

K1 Hinged blade

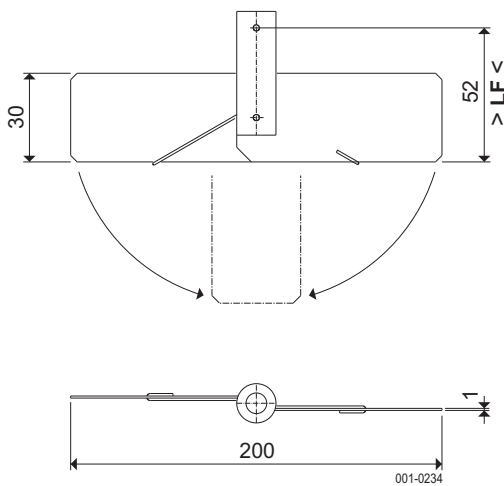

X Blade

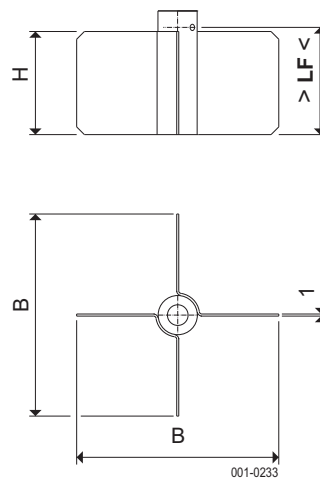

	B	H	LF
X1	98	50	52
X2	98	100	102
X3	180	100	102

Planning information

Pipe thread DIN EN ISO 228-1

DIN ISO 228-1 (substitution for DIN 259)

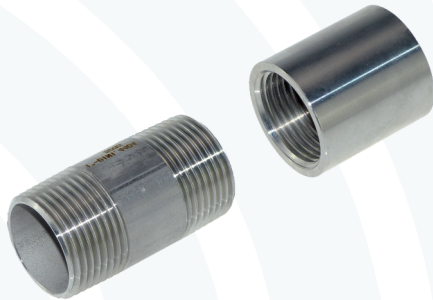

Thread G	Outside Ø mm	Mother-inner Ø mm	Core hole Ø mm	Pitch per Inch	Inclination mm
G 1/8	9.73	8.85	8.80	28	0.907
G 1/4	13.16	11.89	11.80	19	1.337
G 3/8	16.66	15.39	15.25	19	1.337
G 1/2	20.95	19.17	19.00	14	1.814
G 3/4	26.44	24.66	24.50	14	1.814
G 1	33.25	30.93	30.75	11	2.309
G 1 1/4	41.91	39.59	39.25	11	2.309
G 1 1/2	47.80	45.48	45.25	11	2.309
G 2	59.61	57.29	57.00	11	2.309
G 2 1/2	75.18	72.86	72.60	11	2.309
G 3	87.88	85.56	85.30	11	2.309
G 3 1/2	100.33	98.01	97.70	11	2.309
G 4	113.03	110.71	110.40	11	2.309
G 4 1/2	125.73	123.41	123.10	11	2.309
G 5	138.43	136.11	135.70	11	2.309
G 6	163.83	161.51	161.20	11	2.309

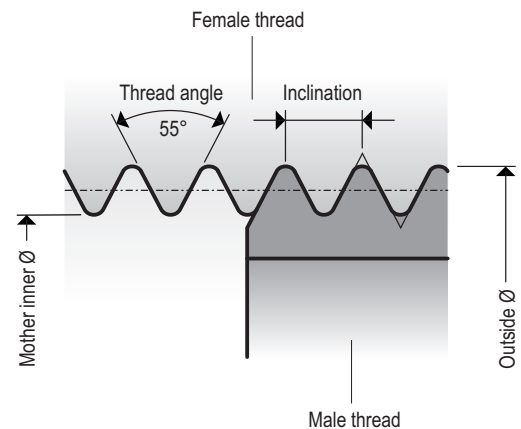
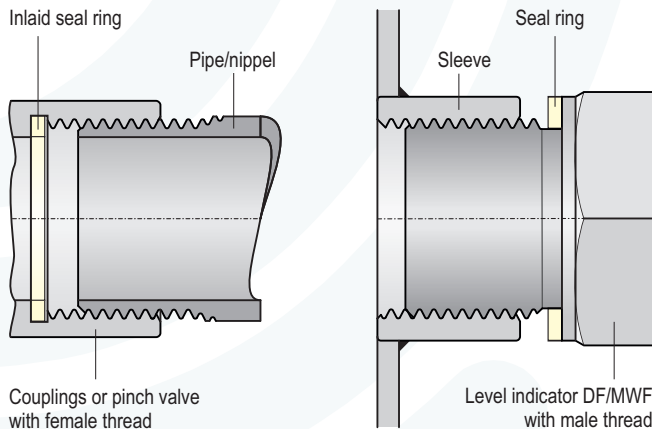

All couplings and pinch valves supplied by MOLLET are manufactured for cylindric connections with **not** metallically sealed threads.

The same applies to the level indicators DF and MWF.

Tightness is achieved by seal rings.

Tightness can also be achieved e.g. with O-rings or sealant adhesive.



According to measurement charts the threads G acc. to DIN EN ISO 228-1 (substitution for DIN 259) have the same dimensions like the threads R acc. to DIN EN 10226-1 (substitution for DIN 2999). However, the tolerances acc. to DIN EN 10226-1 are for the inner diameter in the lower and for the outside diameter in the upper area.

It is therefore possible that cylindric male threads G acc. to DIN EN ISO 228-1 can not be screwed in parts (sleeves) with female threads R that are manufactured acc. to DIN EN 10226-1.

EU-Konformitätserklärung

EU-Declaration of Conformity

Wir/We

MOLLET Füllstandtechnik GmbHIndustriepark RIO 103
D-74706 Osterburken
Tel. 06291 64400 Fax 06291 9846erklären in alleiniger Verantwortung, dass das Produkt:
declares under our sole responsibility, that the product:**Drehflügel-Füllstand-Grenzscharter / Rotary blade limit switch**
Drehflügel-Füllstandanzeiger / Rotary blade level indicatorTyp/Type **DF ...**den folgenden Europäischen Richtlinien entspricht:
conforms with the following European directives:**EMV-Richtlinie** **EMC directive** **2014/30/EU****Niederspannungsrichtlinie** **Low voltage directive** **2014/35/EU**Angewandte harmonisierte Normen oder normative Dokumente:
Applied harmonized standards or normative documents**DIN EN 61326-1:2013** **DIN EN IEC 61000-6-2:2019****DIN EN 61010-1:2020** **DIN EN 60529:2014**Und die Geräte mit  - Kennzeichnung entsprechen zusätzlich der folgenden Europäischen Richtlinie:
And the devices with  - marking conform additional with the following European directive:**ATEX-Richtlinie** **ATEX directive** **2014/34/EU**Je nach Ausführungsvariante angewandte harmonisierte Normen oder normative Dokumente:
Depending on the design applied harmonized standards or normative documents:**DIN EN 1127-1:2019** **DIN EN ISO 80079-36:2016** **DIN EN ISO 80079-37:2016**
DIN EN IEC 60079-0:2019 **DIN EN 60079-1:2015** **DIN EN 60079-7:2016**
DIN EN 60079-31:2014EU-Baumusterprüfbescheinigungsnummer:
EU-Type Examination Certificate:**IBExU04ATEX1001X**
IBExU04ATEX1010X
IBExU04ATEX1033X
IBExU04ATEX1034Ausgestellt von:.
Issued by:

IBExU Institut für Sicherheitstechnik GmbH, 09599 Freiberg (0637)

Qualitätssicherung:
Quality assurance:

TÜV NORD CERT GmbH, 30159 Hannover (0044)

Osterburken, den 03.03.2020,

**Wolfgang Hageleit**
Geschäftsführer / Managing directorDiese Erklärung darf nur unverändert weiterverbreitet werden.
This declaration is only allowed to hand out in unchanged form.