

**Rotary blade level indicator**  
Level limit switch for bulk goods

**DF**

**Operating instructions**

| Index  | Page      |
|--|-----------|
| <b>Safety instructions</b> .....                       | <b>02</b> |
| <b>Operating instructions</b>                          |           |
| 1. <b>Description</b> .....                            | <b>03</b> |
| 2. <b>Installation</b> .....                           | <b>04</b> |
| 3. <b>Electrical connection</b> .....                  | <b>06</b> |
| 4. <b>Switching logics and function displays</b> ..... | <b>06</b> |
| 5. <b>Setting of the sensitivity</b> .....             | <b>07</b> |
| 6. <b>Use of the measuring blades</b> .....            | <b>07</b> |
| 7. <b>Utilization</b> .....                            | <b>08</b> |
| 8. <b>Maintenance and servicing</b> .....              | <b>08</b> |
| 9. <b>Storage</b> .....                                | <b>08</b> |
| 10. <b>Disposal</b> .....                              | <b>08</b> |
| <b>Dimensions</b> .....                                | <b>09</b> |
| <b>Measuring blades</b> .....                          | <b>10</b> |
| <b>EU-Declaration of Conformity</b> .....              | <b>11</b> |

Congratulation, we felicitate to your good choise.  
You have decided for a first class branded product, a rotary blade level indicator from the company MOLLET.

It satisfies highest international standards:

**Functionality, versatileness, long service life and design**

Thank you for having decided for our product.

- Please, read and follow these safety instructions first and take notice of the operating instructions.

## Safety instructions

- 1.1 The installation, initial operation and maintenance may be done by a qualified expert with electrical know-how only.
- 1.2 The connection of the single components as like as measuring blade, anti-buckling protection, shaft extension are permissible only with the attached pins.
- 1.3 For the electrical connection take notice of the local and statutory rules and regulations and/or the VDE 0100.
- 1.4 Before electrical connection, compare the supply voltage with the details at the data plate.
- 1.5 A fuse (with max. 4 A) has to be connected in series to the voltage supply.
- 1.6 Protect the signal contacts from voltage peaks when inductive loads are connected.
- 1.7 The device may put into operation with intact cap-sealing and if it is closed, only.
- 1.8 Switch off the power supply, before opening the device (touchdangerous voltage).



---

### Cable entry

- 2.1 The level indicator will be delivered with a cable gland M20x1.5.
- 2.2 The second drill-hole is closed with a plug screw M20x1.5.  
Optional a further cable gland can be delivered.
- 2.3 The cable gland and the plug screw were screwed on at the factory.  
Please check if the cable gland or the plug screw were loose during the mounting or the transportation. If so, tighten it again.
- 2.4 The cable gland will be delivered with a PE sealing disc. With it, the level indicator is protected against dust and dirt entry during transportation and storage.  
When the indicator is brought into the dusty area it has to be installed immediately at its destine place, the PE sealing disc has to be removed, a cable has to be pulled into the cable gland and the pressure screw has to be screwed on to maintain the type of protection.

#### ATTENTION

Excessive screw on may injure the type of protection



By use in explosive hazardous areas read and follow the

**special conditions and instructions for safe applicate**

of the

**explosive protection information**

first and take notice of the operating instructions.

## Operating instructions

### 1. Description

#### 1.1 Intended use

The electromechanical level limit switch is monitoring the filling level of bulk goods in silos, bunkers, containers, hoppers, weighers, etc..

#### 1.2 Construction

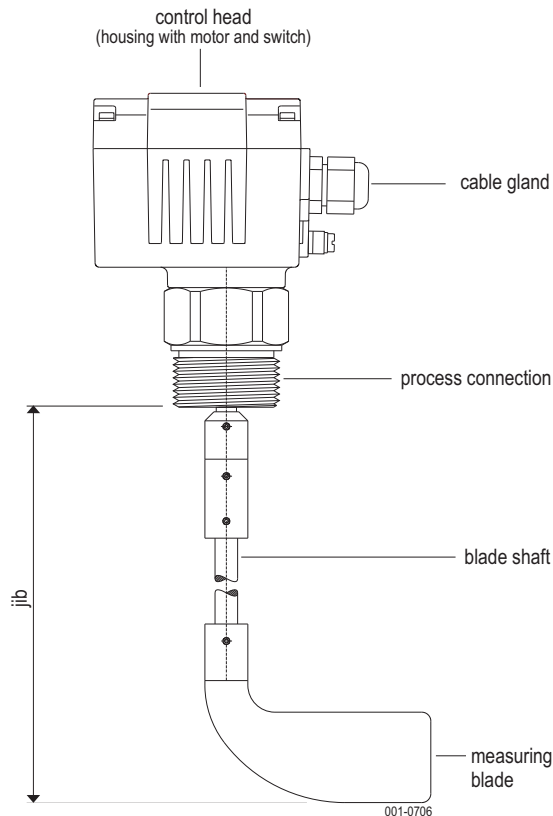

#### 1.3 Function

The rotating measuring blade, projecting into the silo or container, is driven by a gearmotor.

If the bulk material is reaching the measuring blade, the rotation will be hindered and it will be stopped.

The return torque turns the pivoted motor from its end position and actuates the signal switch.

A second switch turns the motor off.

If the filling level of the bulk material sinks, the blade becomes freely again and a spring will turn the motor back into its original end position.

Thereby the motor will be turned on again and the signal switch will be switched back.

#### 1.4 Technical data

|                               |  |
|-------------------------------|--|
| <b>Manufacturer</b>           | <b>MOLLET</b>                              |
|                               | <b>Füllstandtechnik GmbH</b>               |
| <b>Address</b>                | Industriepark RIO 103<br>74706 Osterburken |
| <b>Name</b>                   | rotary blade level indicator               |
| <b>Type</b>                   | <b>DF</b>                                  |
| <b>Bulk goods temperature</b> | <b>T<sub>s</sub></b> see data plate        |
| <b>Ambient temperature</b>    | <b>T<sub>a</sub></b> -20 °C ... +70 °C     |
| <b>Pressure range</b>         | <b>p</b> see data plate                    |
| <b>Measuring blade speed</b>  | 1 U/min                                    |
| <b>Response delay</b>         | approx. 1.20 sec.                          |
| <b>Maintenance</b>            | none                                       |

#### 1.5 Electrical data

|                                |   |
|--------------------------------|---|
| <b>Supply voltage</b>          | see data plate                                      |
| <b>Power consumption</b>       | <b>supply</b> AC 4 VA<br>DC 4 W                     |
| <b>Cable entry</b>             | cable gland M20 x 1.5                               |
| <b>Type of protection</b>      | <b>IP</b> IP 66 acc. to DIN 60529                   |
| <b>Connection clamps</b>       | max. 1.5 mm <sup>2</sup>                            |
| <b>Signal contact</b>          | <b>contact</b> change-over contact<br>potentialfree |
| <b>Switching voltage</b>       | 4 V DC ... 250 V AC                                 |
| <b>Capacity of the contact</b> | 1mA ... 2A  |

The signal contact is a multivoltage and multicurrent switch. It is suitable for use in circuits with low currents and low voltages as well as for medium currents with control voltages up to 250 V ~AC.

#### Caution!

During the whole working life, the switch may be used in the same kind of circuit types, only.

When the switch has been used once with medium switching capacity, it cannot be used any more for the low switching capacity.

#### 1.6 Materials

|                                  |  |
|----------------------------------|--|
| <b>Housing</b>                   | aluminium<br>or<br>stainless steel 1.4401  |
| <b>Process connection</b>        | aluminium<br>or<br>stainless steel 1.4301  |
| <b>Blade shaft</b>               | stainless steel 1.4301   |
| <b>Blade shaft</b>               | stainless steel 1.4301   |
| <b>Measuring blade</b>           | stainless steel 1.4301   |
| <b>Sealing ring</b> (order code) | <b>R0</b> NBR, black<br><b>R1</b> Viton/Teflon/VA<br><b>R2</b> NBR, white, FDA conform<br><b>R5</b> Teflon |

## 2. Installation

### 2.1 Preparation

- Read and follow the safety instructions and the operating instructions before mounting the device!
- Inspect if the delivery is complete.  
The delivery volume is different, depending on the options.

### 2.2 Mounting

#### Thread connection

Put the level indicator together with the sealing at the provided position in the silo or container wall and screw it tightly by means of appropriate tools.

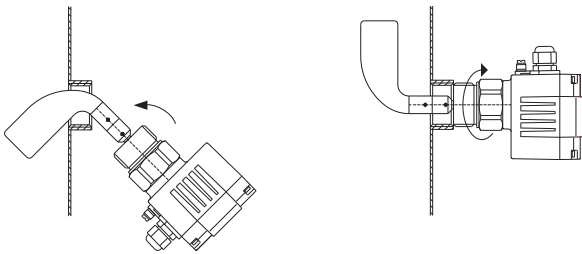

#### Flange connection

Put the level indicator together with the sealing at the container and fix the flange by means of suitable screws.

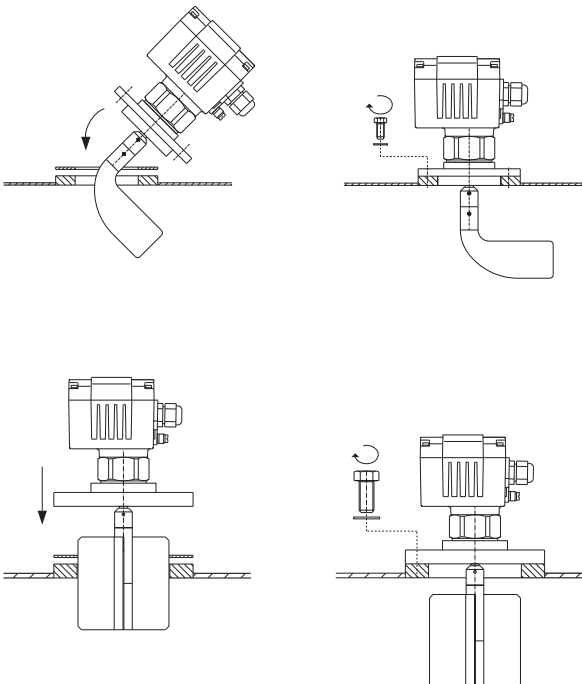

#### Hinged blade

While installation with a hinged blade, please press both parts of the blade together and insert them through the connection socket.

In the container, the blade is unfolding itself.

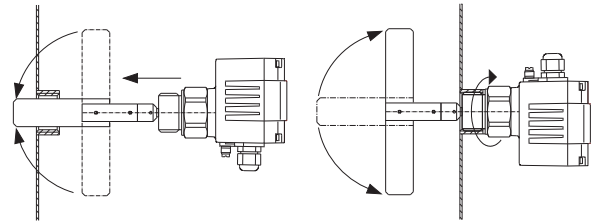

#### Attention!

Make sure the level indicators with thread connection have no deposit of bulk goods inside of the socket.

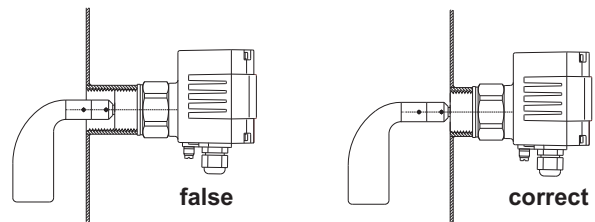

002-0242

The level indicator has to be installed in this way that the jib won't be hit by the filling stream of incoming bulk goods.

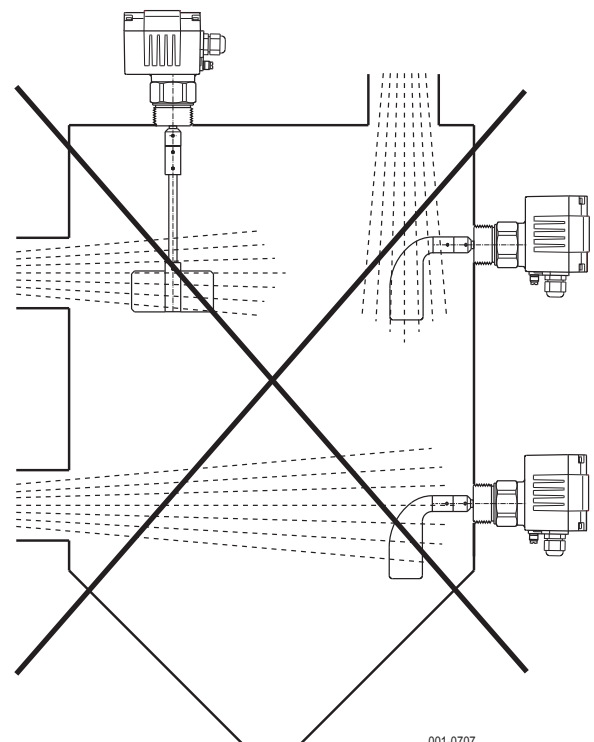

001-0707

**2.3 Mounting of the measuring blades**

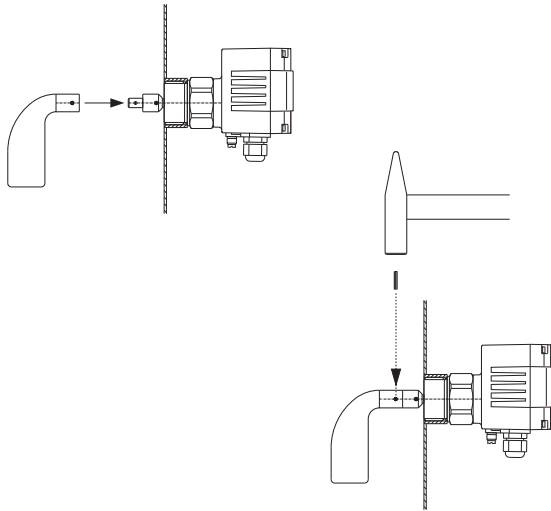

**2.4 Installation of the shaft extension**

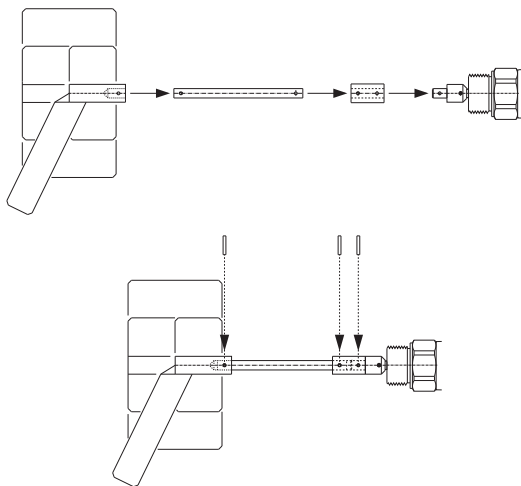

**Attention!**

During beating the pin into the shaft, you have to support the shaft with an adequate counterpart.

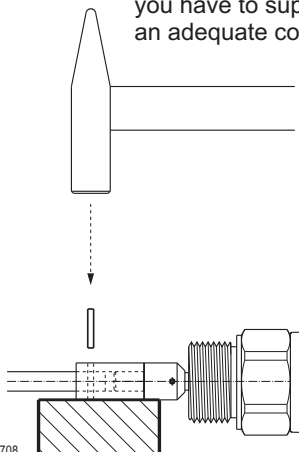

001-0708

**2.5 Orientation of the housing**

After mounting, the housing has to be orientated by turning in such a way, that in case of vertical mounting the cable gland is directed towards the cable duct. In case of all the other mounting positions the cable gland has to be directed vertical to the bottom.

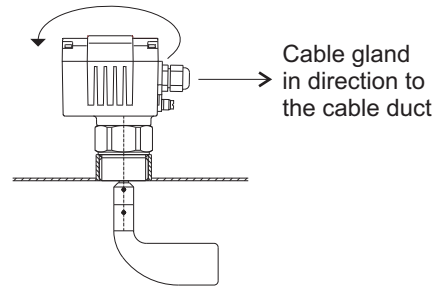

Cable gland  
in direction to  
the cable duct

**Attention!**

Ensure that the cable is fixed tightly in the cable gland.

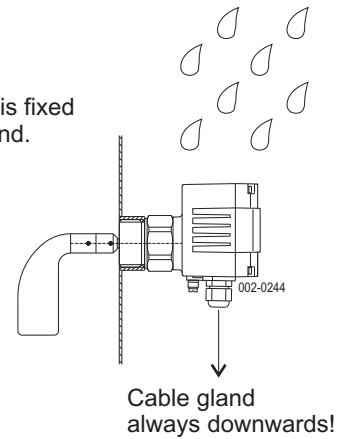

Cable gland  
always downwards!

### 3. Electrical connection

- Install the wiring and electrical connection in compliance with the circuit diagrams.
- Run the cable between housing and cable protection, in order that the switches and the motor will not be hampered at their necessary movement.
- After the electrical connection the cap nut of the cable gland has to be screwed and please ensure that the cable is fixed strongly and tightly in the cable screwing.

#### 3.1 Circuit diagram AC

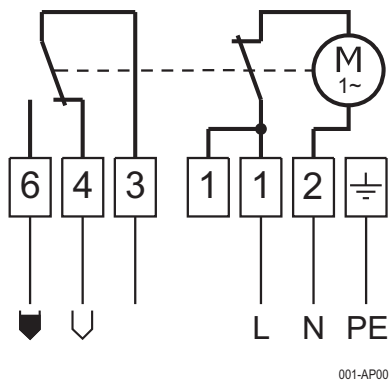

#### 3.2 Circuit diagram DC

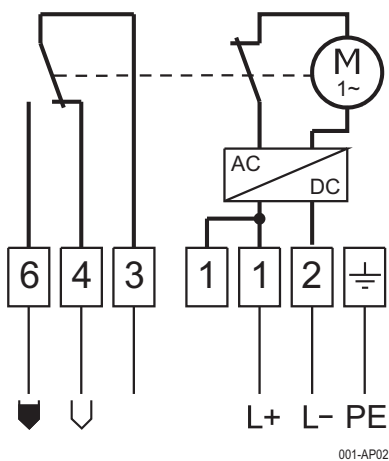

#### Attention!

**Wiring of the level indicator in a way that no undesirable switching function can occur in case of mains voltage failure.**

### 4. Switching logics and function displays

#### Symbol signification

- = under voltage
- = LED "OFF"
- ◡ = full
- ☀ = LED "ON"
- ∪ = empty

#### Arrangement and colours of the LEDs for function display

- yellow ○ ● ● ◡ green
- ∪ green

#### Switching logics

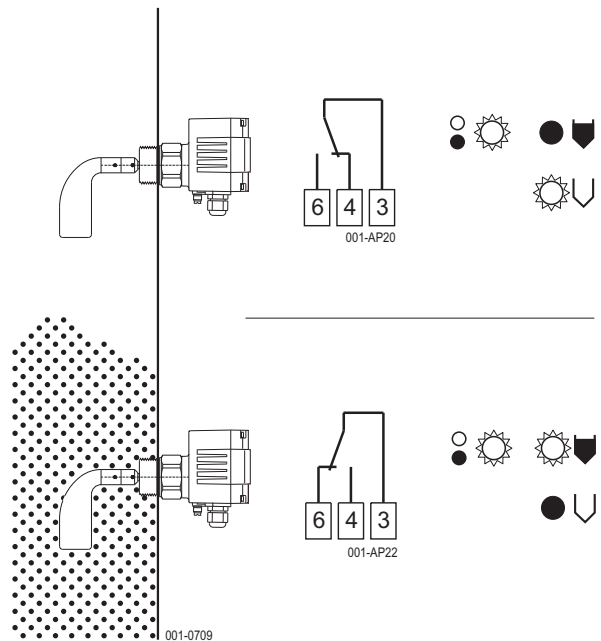

## 5. Setting of the sensitivity

As occasion demands, the sensitivity of the level indicator can be adjusted, referring to the characteristics of the bulk goods, by shifting the spring arm.

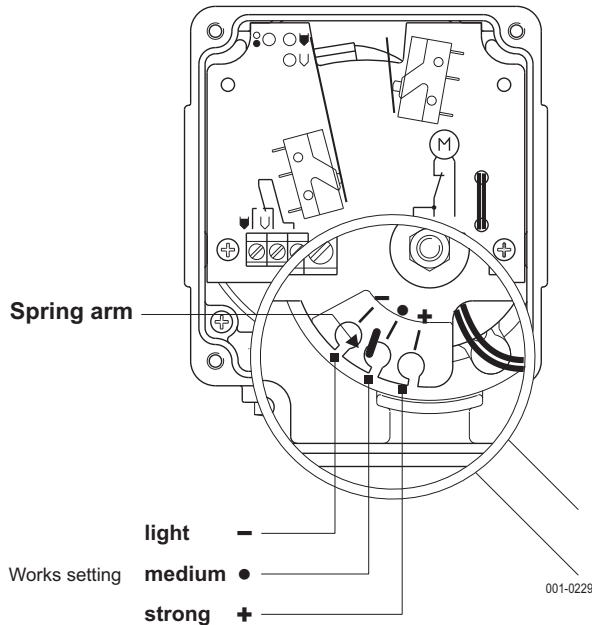

Three settings are possible:

1. **light** for very light bulk goods
2. **medium** suitable for almost all bulk goods
3. **strong** for sticking bulk goods

Fluidised bulk goods are lighter during filling and draining process. This has to be taken appropriately into consideration when setting the spring force and selecting the size of the measuring blade.

## 6. Use of the measuring blades

Lowest bulk density, the measuring blades can be used for.

| Filling level up to 100mm above measuring blade<br>Filling level until measuring blade is compl. covered | Bulk density $\rho_{SS}$ in |                          |
|--|-----------------------------|--------------------------|
|  | kg/l<br>t/m <sup>3</sup>    | t/m <sup>3</sup><br>kg/l |

| Measuring blade      | Blade size | Spring force setting |                      |
|----------------------|------------|----------------------|----------------------|
|                      |            | light                | medium               |
| S1 Socket blade      | 100x30     | $\frac{0,25}{0,4}$   | $\frac{0,35}{0,6}$   |
| S2 Socket blade      | 130x30     | $\frac{0,2}{0,35}$   | $\frac{0,3}{0,5}$    |
| M1 Socket blade      | 90x28      | $\frac{0,15}{0,3}$   | $\frac{0,2}{0,5}$    |
| M2 Socket blade      | 90x40      | $\frac{0,1}{0,2}$    | $\frac{0,15}{0,3}$   |
| T0 Blade T200        | 68x220     | $\frac{0,15}{0,3}$   | $\frac{0,25}{0,5}$   |
| T1 Blade T50         | 98x50      | $\frac{0,15}{0,3}$   | $\frac{0,25}{0,5}$   |
| T2 Blade T100        | 98x100     | $\frac{0,1}{0,2}$    | $\frac{0,2}{0,45}$   |
| T5 Blade T250        | 250x100    | $\frac{0,015}{0,02}$ | $\frac{0,02}{0,03}$  |
| T8 Rubber blade      | 250x100    | $\frac{0,015}{0,02}$ | $\frac{0,02}{0,03}$  |
| X1 Blade X50         | 98x50      | $\frac{0,15}{0,3}$   | $\frac{0,25}{0,5}$   |
| X2 Blade X100        | 98x100     | $\frac{0,1}{0,2}$    | $\frac{0,2}{0,45}$   |
| X3 Blade X200        | 180x100    | $\frac{0,025}{0,05}$ | $\frac{0,075}{0,15}$ |
| XM Blade X40         | 44x50      | $\frac{0,25}{0,4}$   | $\frac{0,35}{0,6}$   |
| K1 Hinged blade T230 | 200x30     | $\frac{0,05}{0,08}$  | $\frac{0,07}{0,12}$  |
| SG Blade             | 126x8      | $\frac{0,45}{0,55}$  | $\frac{0,65}{0,75}$  |
| TG Blade             | 98x8       | $\frac{0,5}{0,6}$    | $\frac{0,7}{0,8}$    |

## 7. Utilization

### 7.1 Putting into operation

- Commissioning of the rotary blade level indicator only, if the installation will be done correctly and if it will be fixed tightly with the electrical contact.
- During operation, the housing and the cable entry must be closed tightly.

### 7.2 Normal operation

- Use the rotary blade level indicator in its intended application only.
- Operate the level indicator within the intended temperature ranges for the ambient and bulk goods temperature.
- Protect the inside of the control head from soiling.
- When the indicator has to be damaged, you have to take the device out of operation immediately.

### 7.3 Inexpert handling

- Ignoring of the safety instructions and the operating instructions.
- Utilization of the rotary blade level indicator in not intended use.
- Mounting of spare parts which are no original parts.
- Remove, adding or change of assembling parts, unless this has been described in the documents of the manufacturer.
- Violation against applicable law and standards.

---

## 8. Maintenance and servicing

### 8.1 Maintenance

- In case of intended use, the rotary blade level indicator needs no maintenance.
- Remove deposits and stickings from the blades or wrinkles with a brush or with a scraper. Don't use any force and don't damage the sealing of the shaft.
- Inspect the assemblings inside of the container about signs of wear and tear, in regular intervals. Define the intervals of the control, depending on the bulk goods characteristics.

### 8.2 Servicing

- Damaged parts, contacts or connections have to be repaired immediately or being replaced with parts of the same kind.
- Until the complete restoration of the proper function, the rotary blade level indicator must not be used any more.

## 9. Storage

- While storage, the level indicator has to be protected from dust and humidity.
- Please ensure that the shaft of level indicators with jib extension will not be buckled or bended.

---

## 10. Disposal

- The level indicator can be recycled.
  - The disposal applies to the valid environmental guidelines according to the location of the carrier and the local manufacturing conditions.
-



**Dimensions**

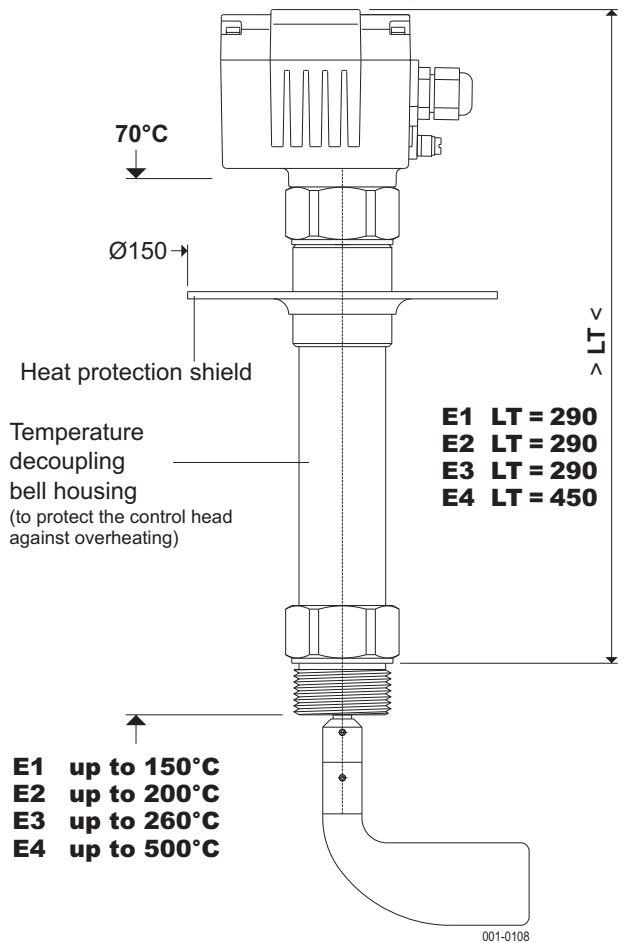
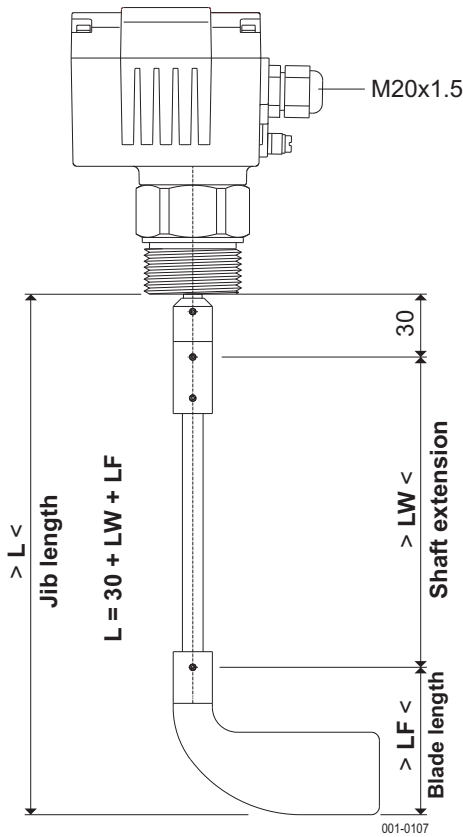
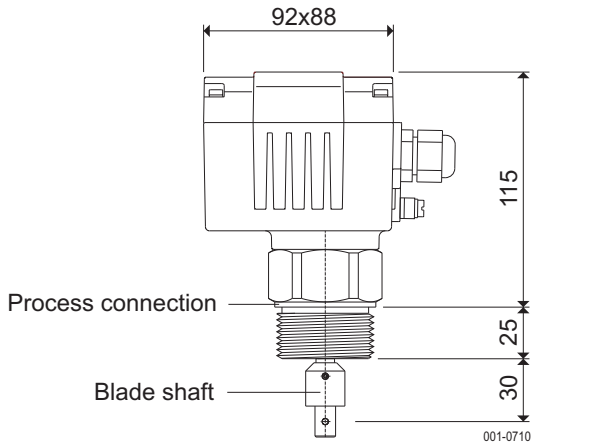

**Application instructions**

Mounting position any  
Loadability of the blades  $F_1$  max. **50 Nm**

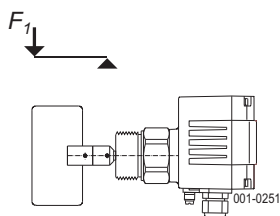

For use in higher loads and as an empty indicator, the installation of a protection roof is recommended.

Or use DF23 / DF24 with reinforced blade shaft.

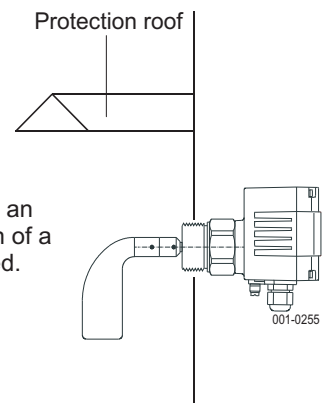

**Measuring blades**

**S2 Socket blade**

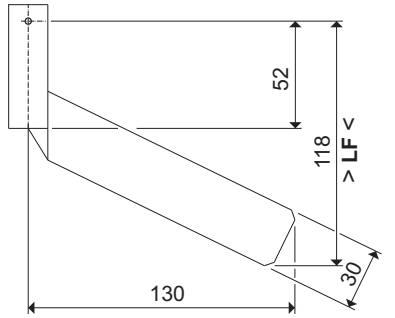

S2V reinforced, 2 mm

**T0 Blade**

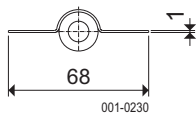
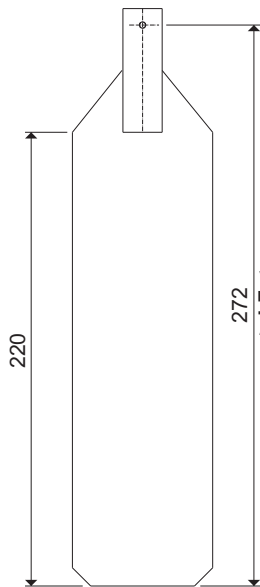

**K1 Hinged blade**

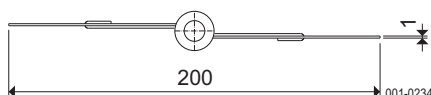
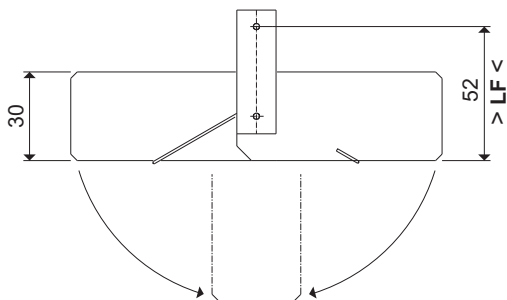

**M Socket blade**

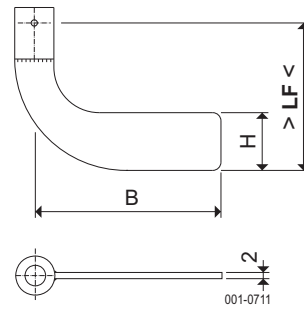

|    | B  | H  | LF |
|----|----|----|----|
| M1 | 90 | 28 | 72 |
| M2 | 90 | 40 | 70 |

**T Blade**

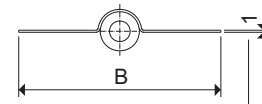
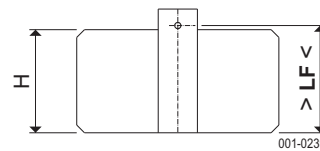

T1V and T2V reinforced, 2 mm thick

|                  | B   | H   | LF  |
|------------------|-----|-----|-----|
| T1               | 98  | 50  | 52  |
| T2               | 98  | 100 | 102 |
| T3               | 200 | 100 | 102 |
| T5               | 250 | 100 | 102 |
| T8 <sup>1)</sup> | 250 | 100 | 102 |

<sup>1)</sup> blades 10 mm thick  
in rubber NBR, black

**X Blade**

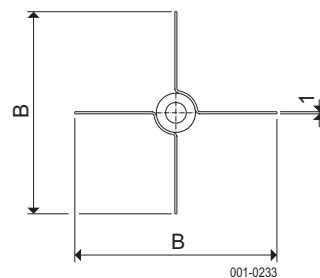
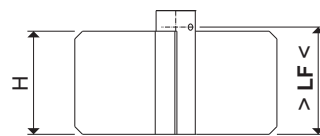

|    | B   | H   | LF  |
|----|-----|-----|-----|
| X1 | 98  | 50  | 52  |
| X2 | 98  | 100 | 102 |
| X3 | 180 | 100 | 102 |

## Planning information

### Pipe thread DIN EN ISO 228-1

DIN ISO 228-1 (substitution for DIN 259)

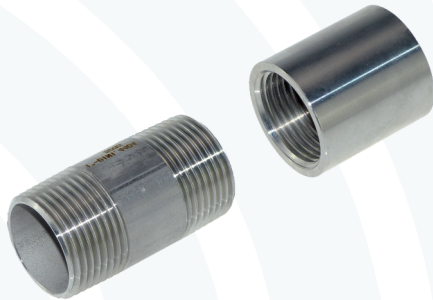

| Thread G | Outside Ø mm | Mother-inner Ø mm | Core hole Ø mm | Pitch per Inch | Inclination mm |
|----------|--------------|-------------------|----------------|----------------|----------------|
| G 1/8    | 9.73         | 8.85              | 8.80           | 28             | 0.907          |
| G 1/4    | 13.16        | 11.89             | 11.80          | 19             | 1.337          |
| G 3/8    | 16.66        | 15.39             | 15.25          | 19             | 1.337          |
| G 1/2    | 20.95        | 19.17             | 19.00          | 14             | 1.814          |
| G 3/4    | 26.44        | 24.66             | 24.50          | 14             | 1.814          |
| G 1      | 33.25        | 30.93             | 30.75          | 11             | 2.309          |
| G 1 1/4  | 41.91        | 39.59             | 39.25          | 11             | 2.309          |
| G 1 1/2  | 47.80        | 45.48             | 45.25          | 11             | 2.309          |
| G 2      | 59.61        | 57.29             | 57.00          | 11             | 2.309          |
| G 2 1/2  | 75.18        | 72.86             | 72.60          | 11             | 2.309          |
| G 3      | 87.88        | 85.56             | 85.30          | 11             | 2.309          |
| G 3 1/2  | 100.33       | 98.01             | 97.70          | 11             | 2.309          |
| G 4      | 113.03       | 110.71            | 110.40         | 11             | 2.309          |
| G 4 1/2  | 125.73       | 123.41            | 123.10         | 11             | 2.309          |
| G 5      | 138.43       | 136.11            | 135.70         | 11             | 2.309          |
| G 6      | 163.83       | 161.51            | 161.20         | 11             | 2.309          |

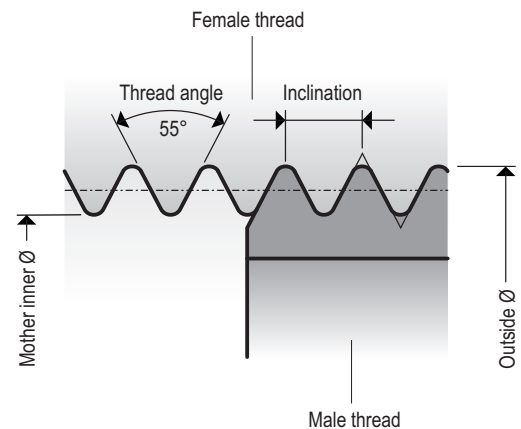
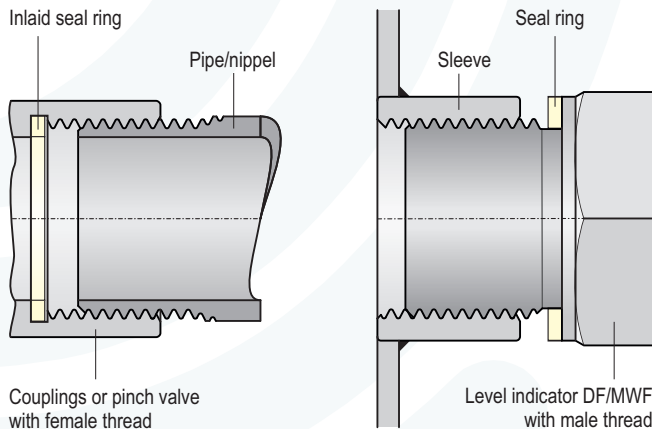

All couplings and pinch valves supplied by MOLLET are manufactured for cylindric connections with **not** metallically sealed threads.

The same applies to the level indicators DF and MWF.

Tightness is achieved by seal rings.

Tightness can also be achieved e.g. with O-rings or sealant adhesive.

According to measurement charts the threads G acc. to DIN EN ISO 228-1 (substitution for DIN 259) have the same dimensions like the threads R acc. to DIN EN 10226-1 (substitution for DIN 2999). However, the tolerances acc. to DIN EN 10226-1 are for the inner diameter in the lower and for the outside diameter in the upper area.

It is therefore possible that cylindric male threads G acc. to DIN EN ISO 228-1 can not be screwed in parts (sleeves) with female threads R that are manufactured acc. to DIN EN 10226-1.

## EU-Konformitätserklärung EU-Declaration of Conformity

Wir/We

**MOLLET Füllstandtechnik GmbH**

Industriepark RIO 103  
D-74706 Osterburken  
Tel. 06291 64400 Fax 06291 9846

erklären in alleiniger Verantwortung, dass das Produkt:  
declares under our sole responsibility, that the product:

**Drehflügel-Füllstand-Grenzschalter / Rotary blade limit switch**  
Drehflügel-Füllstandanzeiger / Rotary blade level indicator

Typ/Type **DF ...**

den folgenden Europäischen Richtlinien entspricht:  
conforms with the following European directives:



**EMV-Richtlinie**                      **EMC directive**                      **2014/30/EU**

**Niederspannungsrichtlinie**      **Low voltage directive**              **2014/35/EU**

Angewandte harmonisierte Normen oder normative Dokumente:  
Applied harmonized standards or normative documents

**DIN EN 61326-1:2013**                      **DIN EN IEC 61000-6-2:2019**

**DIN EN 61010-1:2020**                      **DIN EN 60529:2014**

Und die Geräte mit  - Kennzeichnung entsprechen zusätzlich der folgenden Europäischen Richtlinie:  
And the devices with  - marking conform additional with the following European directive:

**ATEX-Richtlinie**                      **ATEX directive**                      **2014/34/EU**

Je nach Ausführungsvariante angewandte harmonisierte Normen oder normative Dokumente:  
Depending on the design applied harmonized standards or normative documents:

**DIN EN 1127-1:2019**                      **DIN EN ISO 80079-36:2016**              **DIN EN ISO 80079-37:2016**  
**DIN EN IEC 60079-0:2019**              **DIN EN 60079-1:2015**                      **DIN EN 60079-7:2016**  
**DIN EN 60079-31:2014**

EU-Baumusterprüfbescheinigungsnummer:  
EU-Type Examination Certificate:

**IBExU04ATEX1001X**  
**IBExU04ATEX1010X**  
**IBExU04ATEX1033X**  
**IBExU04ATEX1034**

Ausgestellt von:.  
Issued by:

IBExU Institut für Sicherheitstechnik GmbH, 09599 Freiberg (0637)

Qualitätssicherung:  
Quality assurance:

TÜV NORD CERT GmbH, 30159 Hannover (0044)

Osterburken, den 03.03.2020,



**Wolfgang Hageleit**  
Geschäftsführer / Managing director

Diese Erklärung darf nur unverändert weiterverbreitet werden.  
This declaration is only allowed to hand out in unchanged form.