

Rotary blade level indicator
Level limit switch for bulk goods

DF

Operating instructions

Index	Page
Safety instructions	02
Operating instructions	
1. Description	02
2. Installation	03
3. Electrical connection	04
4. Switching logics and function displays	04
5. Setting of the sensitivity	05
6. Utilization	05
7. Maintenance and servicing	05
8. Storage	05
9. Disposal	05
Dimensions	06

Congratulation, we felicitate to your good choise.
You have decided for a first class branded product, a rotary
blade level indicator from the company **MOLLET**.

It satisfies highest international standards:

Functionality, versatility, long service life and design

Thank you for having decided for our product.

► Please, read and follow these safety instructions first and take notice of the operating instructions.

Safety instructions

1. The installation, initial operation and maintenance may be done by a qualified expert with electrical know-how only.
2. The connection of the single components as like as measuring blade, anti-buckling protection, shaft extension are permissible only with the attached pins.
3. For the electrical connection take notice of the local and statutory rules and regulations and/or the VDE 0100.
4. Before electrical connection compare the supply voltage with the details at the data plate.
5. A fuse (with max. 4A) has to be connected in series to the voltage supply.
6. Protect the signal contacts from voltage peaks when inductive loads are connected.
7. The device may put into operation if it is closed, only.
8. Switch off the power supply, before opening the device.



Operating instructions

1. Description

1.1 Intended use

The electromechanical level limit switch is monitoring the filling level of bulk goods in silos, bunkers, containers, hoppers, weighers, etc..

1.2 Construction

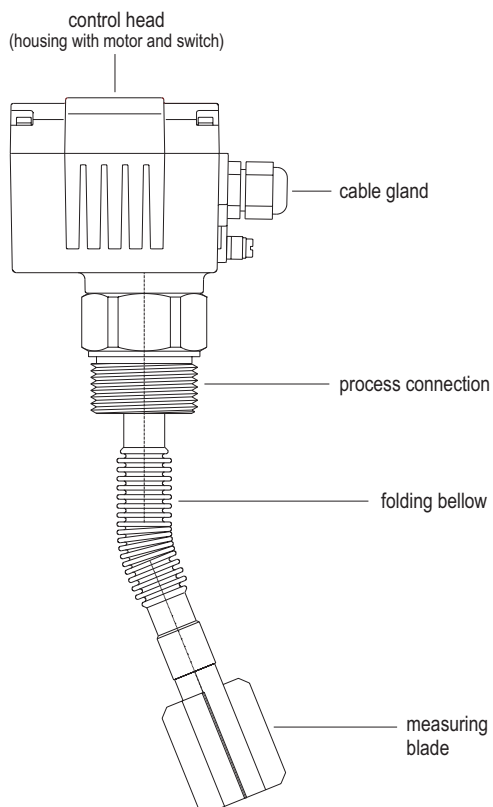

1.3 Function

The rotating measuring blade, projecting into the silo or container, is driven by a gearmotor.

If the bulk material is reaching the measuring blade, the rotation will be hindered and it will be stopped.

The return torque turns the pivoted motor from its end position and actuates the signal switch.

A second switch turns the motor off.

If the filling level of the bulk material sinks, the blade becomes freely again and a spring will turn back the motor into its original end position.

Thereby the motor will be turned on again and the signal switch will be switched back.

1.4 Technical data

Manufacturer	MOLLET Füllstandtechnik GmbH
Address	Industriepark RIO 103 74706 Osterburken
Name	rotary blade level indicator
Type	DF
Bulk goods temperature	T_s see data plate
Ambient temperature	T_a -20 °C ... +70 °C
Pressure range	p -0,5 bar ... 5 bar
Measuring blade speed	1 U/min
Response delay	approx. 1.20 sec.
Maintenance	none

1.5 Materials

Housing	aluminium or stainless steel 1.4401
Process connection	stainless steel 1.4301
Folding bellow	stainless steel 1.4301
Measuring blade	stainless steel 1.4301

2. Installation

2.1 Preparation

- Read and follow the safety instructions and the operating instructions before mounting the device!
- Inspect if the delivery is complete.
The delivery volume is different, depending on the options.

2.2 Mounting

Thread connection

Put the level indicator together with the sealing at the provided position in the silo or container wall and screw it tightly by means of appropriate tools.

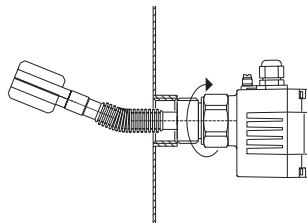
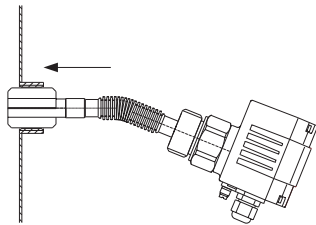

Flange connection

Put the level indicator together with the sealing at the container and fix the flange by means of suitable screws.

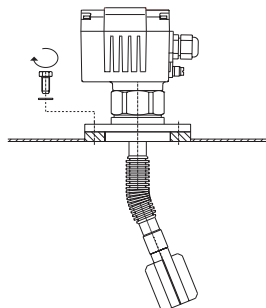
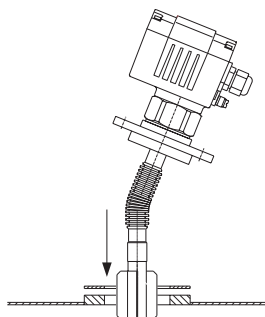

2.3 Orientation of the housing

After mounting, the housing has to be orientated by turning in such a way, that in case of vertical mounting the cable gland is directed towards the cable duct. In case of all the other mounting positions the cable gland has to be directed vertical to the bottom.

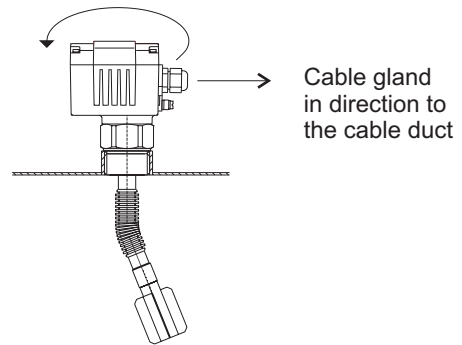

Attention!

Ensure that the cable is fixed tightly in the cable gland.

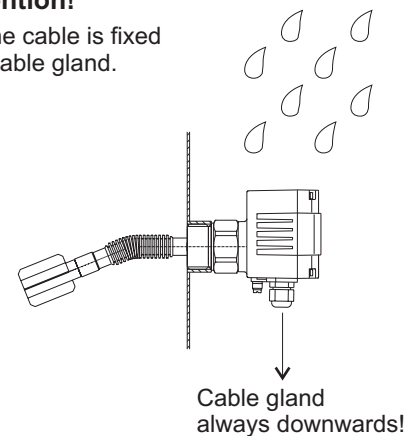

3. Electrical connection

3.1 Electrical data

Supply voltage	see data plate
Power consumption	supply AC 4 VA DC 4 W
Cable entry	cable gland M20 x 1.5
Type of protection	IP IP 66 acc. to DIN 60529
Connection clamps	max. 1.5 mm ²
Signal contact	contact change-over contact potentialfree
Switching voltage	4 V DC ... 250 V AC
Capacity of the contact	1mA ... 2A

The signal contact is a multivoltage and multicurrent switch. It is suitable for use in circuits with low currents and low voltages as well as for medium currents with control voltages up to 250 V ~AC.

Caution!

During the whole working life, the switch may be used in the same kind of circuit types, only. When the switch has been used once with medium switching capacity, it cannot be used any more for the low switching capacity.

3.2 Electrical connection

- Install the wiring and electrical connection in compliance with the circuit diagrams.
- Run the cable between housing and cable protection, in order that the switches and the motor will not be hampered at their necessary movement.
- After the electrical connection the cap nut of the cable gland has to be screwed and please ensure that the cable is fixed strongly and tightly in the cable screwing.

3.3 Circuit diagram AC

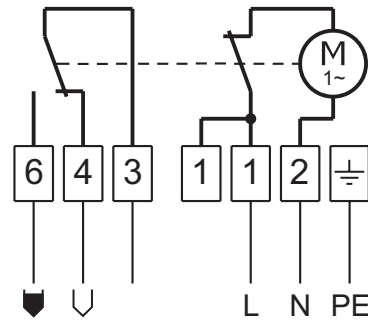

3.4 Circuit diagram DC

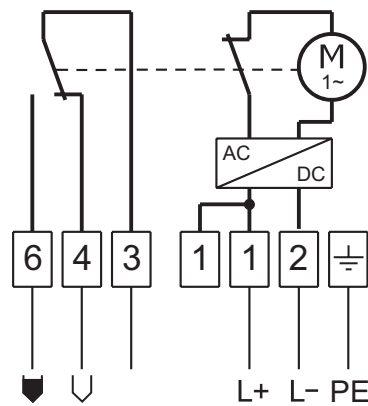

Attention!

Wiring of the level indicator in a way that no undesirable switching function can occur in case of mains voltage failure.

4. Switching logics and function displays

Symbol signification

○ = under voltage	● = LED "OFF"
⬇ = full	☀ = LED "ON"
⬇ = empty	

Arrangement and colours of the LEDs for function display

yellow	○ ● ● ⬇	green
	● ⬇	green

Switching logics

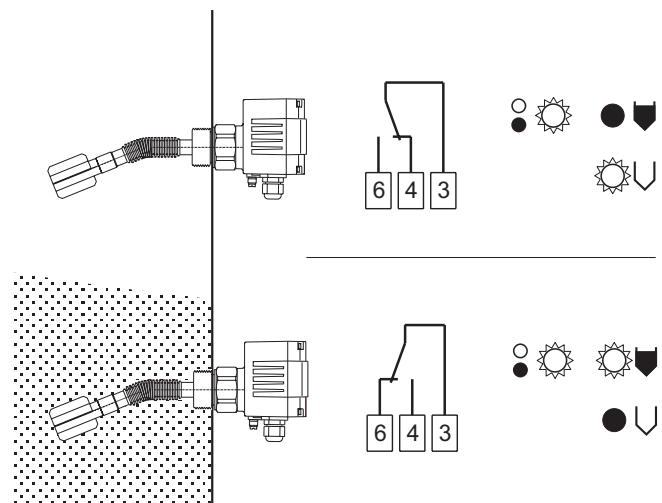

5. Setting of the sensitivity

As occasion demands, the sensitivity of the level indicator can be adjusted, referring to the characteristics of the bulk goods, by shifting the spring arm.

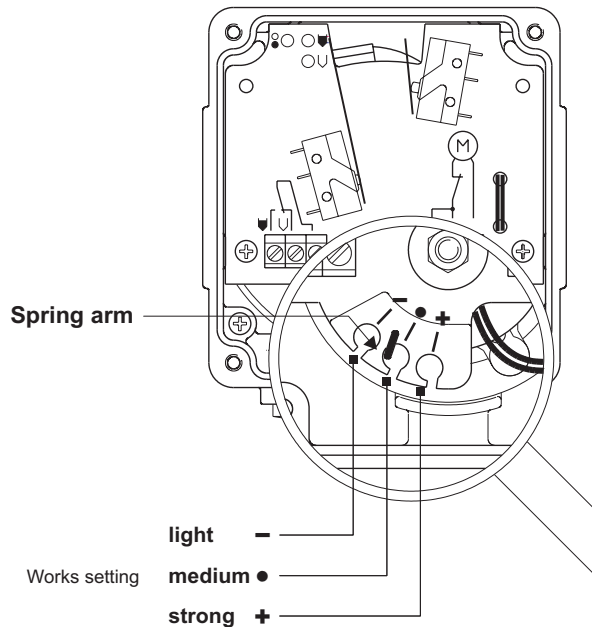

Three settings are possible:

1. **light** for very light bulk goods
2. **medium** suitable for almost all bulk goods
3. **strong** for sticking bulk goods

Fluidised bulk goods are lighter during filling and draining process. This has to be taken appropriately into consideration when setting the spring force and selecting the size of the measuring blade.

6. Utilization

6.1 Putting into operation

- Commissioning of the rotary blade level indicator only, if the installation will be done correctly and if it will be fixed tightly with the electrical contact.
- During operation, the housing and the cable entry must be closed tightly.

6.2 Normal operation

- Use the rotary blade level indicator in its intended application only.
- Operate the level indicator within the intended temperature ranges for the ambient and bulk goods temperature.
- Protect the inside of the control head from soiling.
- When the indicator has to be damaged, you have to take the device out of operation immediately.

6.3 Inexpert handling

- Ignoring of the safety instructions and the operating instructions.
- Utilization of the rotary blade level indicator in not intended use.
- Mounting of spare parts which are no original parts.
- Remove, adding or change of assembling parts, unless this has been described in the documents of the manufacturer.
- Violation against applicable law and standards.

7. Maintenance and servicing

7.1 Maintenance

- In case of intended use, the rotary blade level indicator needs no maintenance.
- Remove deposits and stickings from the blades or wrinkles with a brush or with a scraper. Don't use any force and don't damage the sealing of the shaft.
- Inspect the assemblies inside of the container about signs of wear and tear, in regular intervals. Define the intervals of the control, depending on the bulk goods characteristics.

7.2 Servicing

- Damaged parts, contacts or connections have to be repaired immediately or being replaced with parts of the same kind.
- Until the complete restoration of the proper function, the rotary blade level indicator must not be used any more.

8. Storage

- While storage, the level indicator has to be protected from dust and humidity.
- Please ensure that the shaft of level indicators with jib extension will not be buckled or bended.

9. Disposal

- The level indicator can be recycled.
- The disposal applies to the valid environmental guidelines according to the location of the carrier and the local manufacturing conditions.

Dimensions

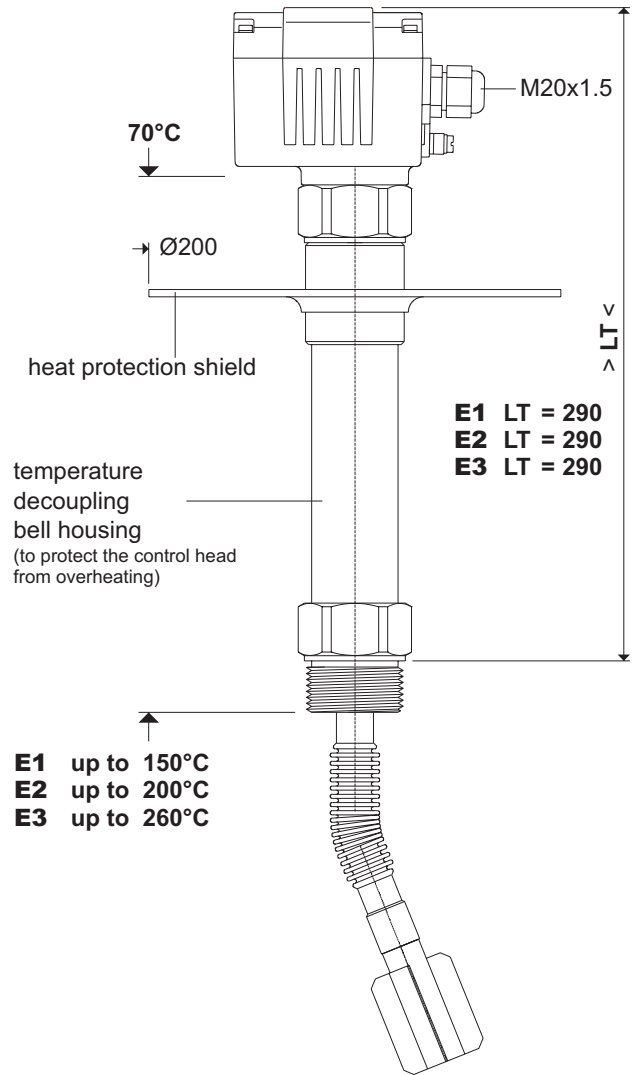
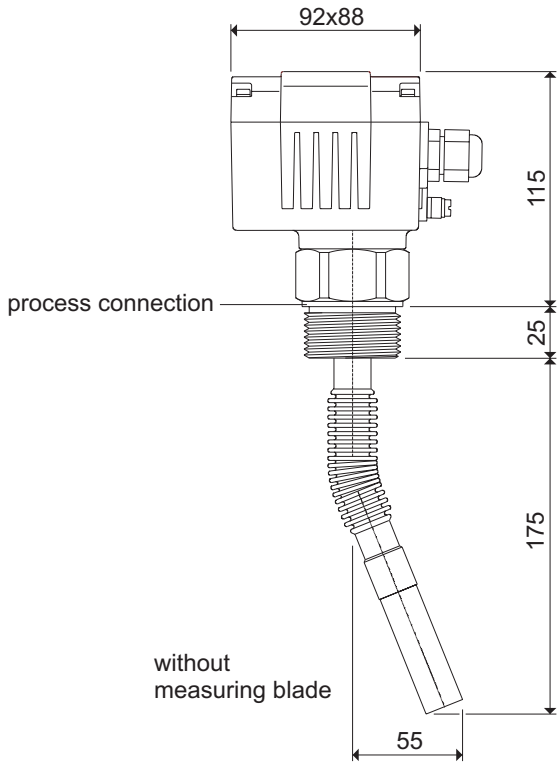

XM Blade

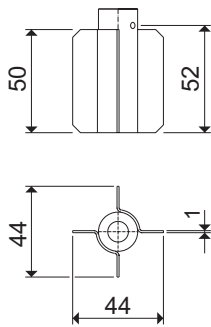

Application instructions

Mounting position any
Loadability of the blades F_1 max. 20 Nm

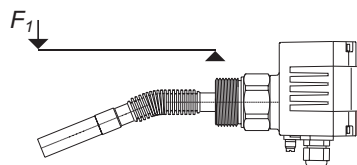

For use in higher loads and as an empty indicator, the installation of a protection roof is recommended.

