

Process connection - threads

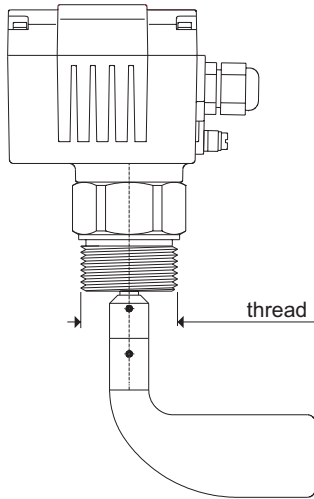

	G1 G1"	G2 G1¼"	G3 G1½"	G4 G2"	G5 M30	G6 M32
DF11	X	X	X		X	X
DF21	X	X	X		X	X
DF22	X	X	X			
DF23		X	X	X		
DF24				X		
DF26		X	X			
DF27		X	X			
DF28		X	X			
DF29		X	X			
DF30	X		X			
DF31			X			
DF32			X			

G acc. to ISO DIN 228 M fine thread, 1.5 mm pitch

mounting variations

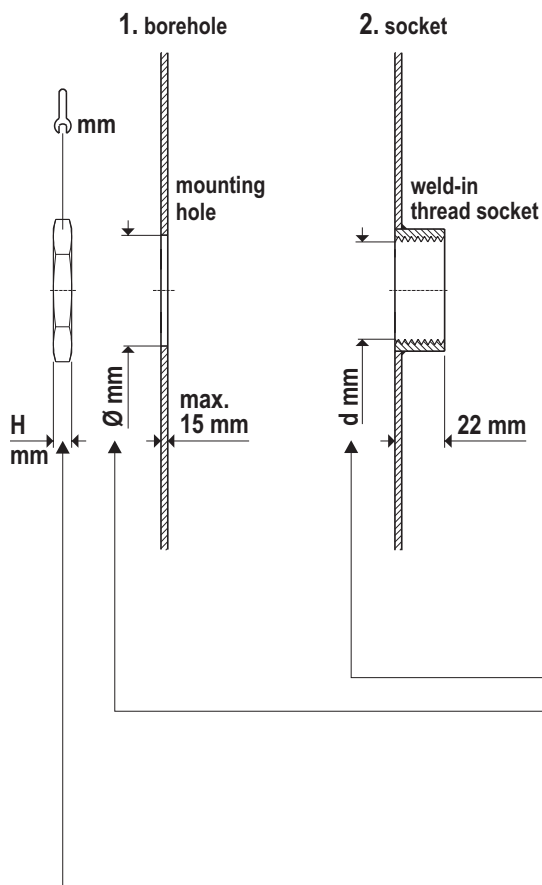

Take notice of the blade dimensions

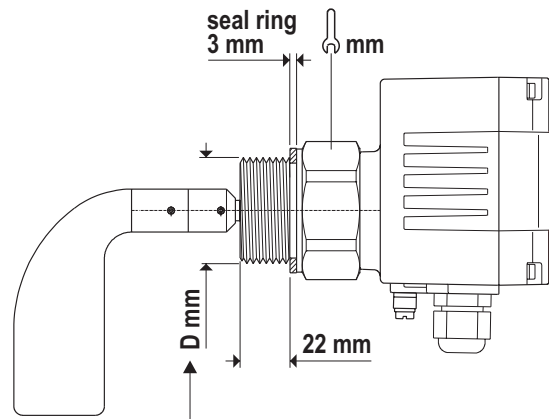

	G1 G1"	G2 G1¼"	G3 G1½"	G4 G2"	G5 M30	G6 M32
D mm	33.25	41.91	47.80	59.61	30.00	32.00
d mm	30.29	38.95	44.85	56.66	28.38	30.35
Ø mm	35.00	44.00	50.00	62.00	32.00	34.00

G acc. to ISO DIN 228 M fine thread, 1.5 mm pitch

Hexagonal nuts

Type	DF-SM1	DF-SM2	DF-SM3	DF-SM4	DF-SM5	DF-SM6
H mm	6	8	8	10	6	6

mm	41	50	55	75	41	41
----	----	----	----	----	----	----