

Explosion protection information



Gas+
Dust
hybrid mixtures

	Index	Page
ATEX	Hybrid mixtures - atmospheric conditions Non-atmospheric conditions	12
1/2G	Marking according to ATEX 95 - details on type plate	13
	Equipment category appropriation by zones	14
	Ambient temperature Ta, maximum surface temperature T, TX in zone 0.	15
IP66	Ambient temperature Ta	16
	Maximum surface temperature T, TX	17
T80°C	Pressure, vacuum p, p (process)	18
CE	Special conditions and instructions for safe application	20

Hybrid mixtures (mixtures which contain combustible dusts, combustible gases resp. vapours and air at the same time)

Hybrid mixtures are mixtures of substances comprising dusts and combustible gases which can occur in the production or processing of products containing solvents for example or as a result of escaping smouldering gas from overheated products in dust form.

These addition of two hazardous substances result in variance of the explosion characteristics.

To be mentioned are the extension of the explosion limits, increasing explosion pressure and the explosion frequency as well as the reduction of the minimum ignition temperature.

The ignition of an explosive gas or vapour atmosphere or the ignition of a so-called hybrid mixture must be expected in the case of the presence of combustible gases or vapours, depending on their concentration.

Atmospheric conditions

Valid as atmospheric conditions are total pressures

from **0.8 bar up to 1.1 bar absolute**
(equivalent to -0.2 bar up to +0.1 bar)

and temperatures in mixtures

from **-20 °C up to +60 °C**

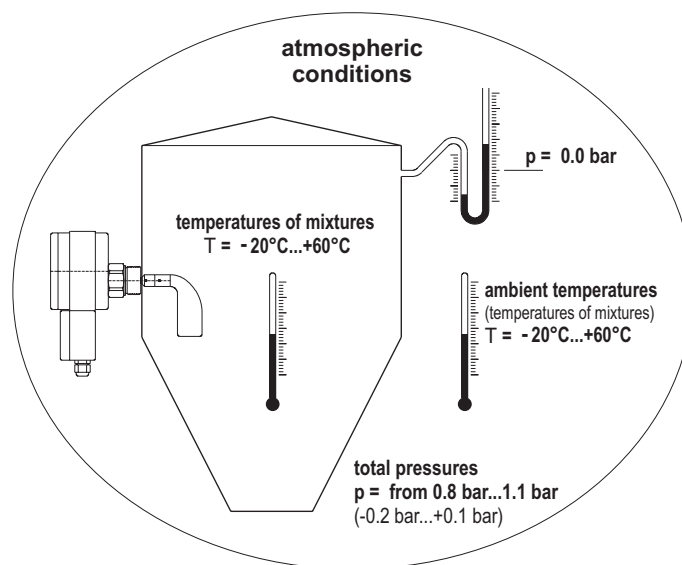

Deviating atmospheric conditions

Deviating atmospheric conditions are given when a higher or lower pressure and/ or a higher or lower temperature exists in the silo or container than given externally, but the deviating values are still within the atmospheric conditions.

Non-atmospheric conditions

Frequently silo plants and containers are operated with combustible bulk goods inside under non-atmospheric conditions, for example, dryers with higher temperatures or containers under low or high pressure.

No EC-type-examination certificates and/or declarations of conformity are available for apparatus under these operation conditions and in principle they also cannot be available because of a lack of legal basis in Germany.

Here, in principle is called for the expertise of the operator or of a suitable consultancy agency.

Helpful in special cases is to have a test, for example carried out by a "Notified Body" under the specific application conditions.

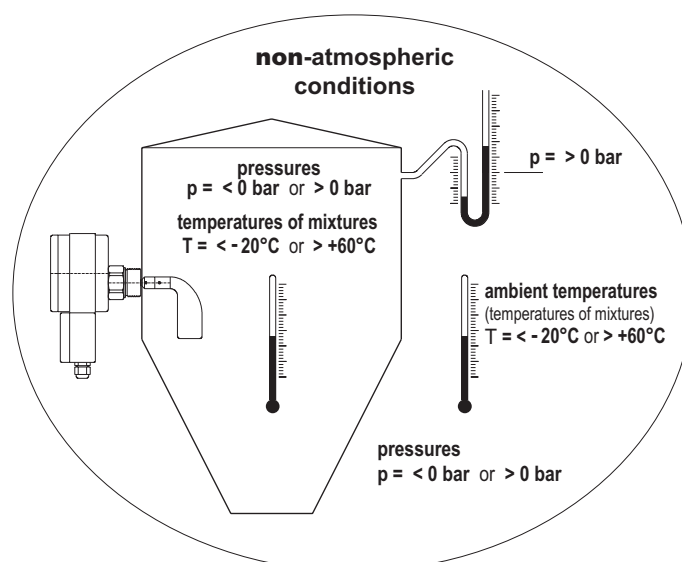

Marking in accordance with ATEX 95

Marking on rotary blade level indicators DF for use in potentially gas and dust explosive atmospheres

Ex II 1D2G / 2GD EEx de IIB T6 T70°C IP66

Electrical part

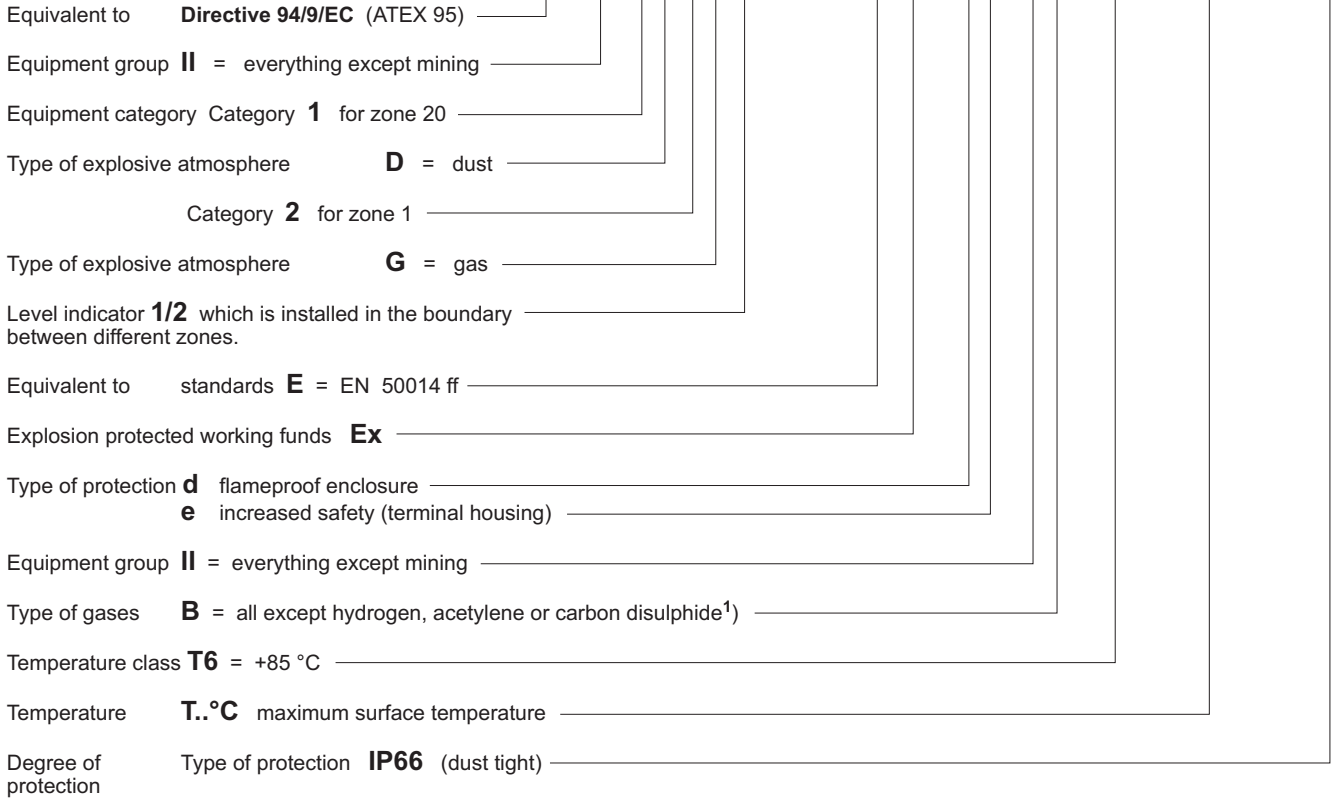

Non-electrical part Type of protection **C** constructive safety
Temperature **TX** maximum surface temperature with symbol X for special instructions

¹⁾ In the case of hydrogen, acetylene or carbon disulphide, please contact us

Type label details

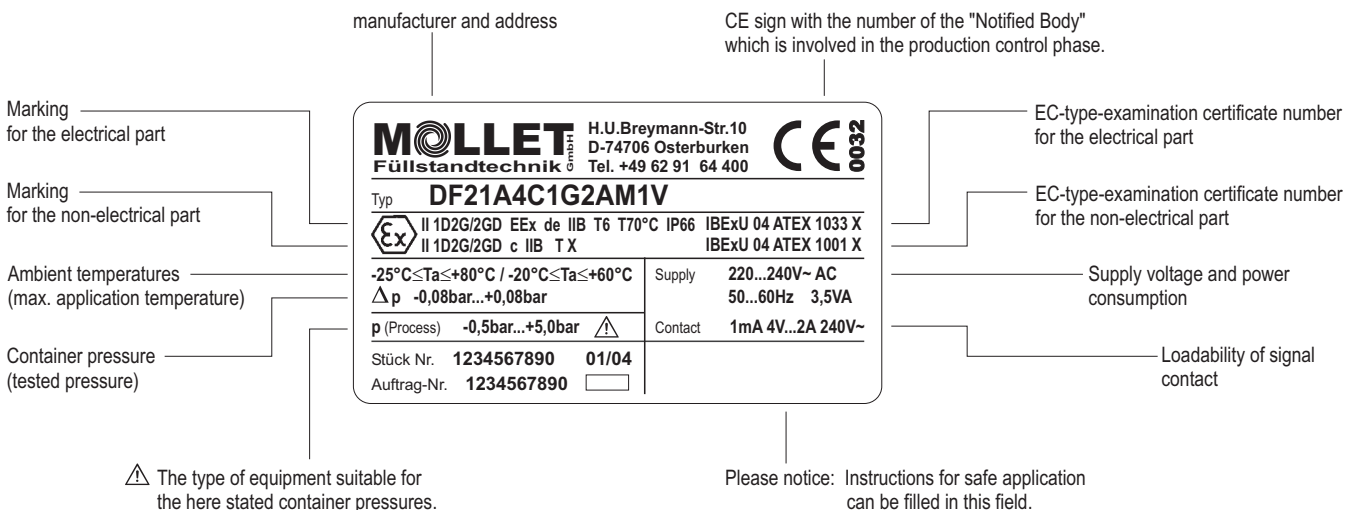

Note: The X behind the certification number indicates special conditions for the safe application of the equipment in the appendix to the EC-type-examination certificate.

Equipment category appropriation by zones



Installation in the boundary between different zones, whereas zone 0 is inside.

Order code **A3** or **A4** and **DF-ZT**

Marking:

II 1D2G / 2GD electrical part

II 1GD / 2GD non-electrical part **DF-ZT**

		H.U.Breymann-Str.10 D-74706 Osterburken Tel. +49 62 91 64 400		
Typ DF21A3C1G2AM1V				
	II 1D2G/2GD EEx de IIB T6 T70°C IP66 IBExU 04 ATEX 1033 X		Supply 220...240V~ AC	
	II 1D2G/2GD c IIB T X IBExU 04 ATEX 1001 X		50...60Hz 3,5VA	
-25°C ≤ Ta ≤ +80°C / -20°C ≤ Ta ≤ +60°C		Δ p -0,08bar...+0,08bar		Contact 1mA 4V...2A 240V~
p (Process) -0,5bar...+5,0bar		Stück Nr. 1234567890 01/04		
Auftrag-Nr. 1234567890		A.-Nr. <input type="checkbox"/>		

Type label for zone separating element:

		H.U.Breymann-Str.10 D-74706 Osterburken Tel. +49 62 91 64 400		
Typ DF-ZT				
	II 1GD/2GD c IIB T X IBExU 04 ATEX 1001 X		Stück Nr. 1234567890 - 01/04	
	-25°C ≤ Ta ≤ +80°C / -20°C ≤ Ta ≤ +70°C		A.-Nr. 1234567890 <input type="checkbox"/>	
p (Process) -0,1bar...+5bar				

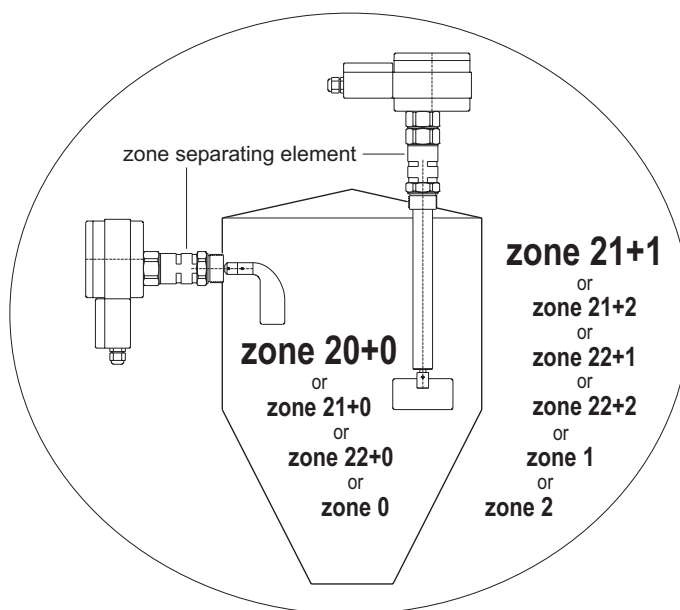

Installation in the boundary between different zones.



Any zone combination is valid.

Order code **A3** or **A4**

Marking:

II 1D2G / 2GD electrical part

II 1D2G / 2GD non-electrical part

		H.U.Breymann-Str.10 D-74706 Osterburken Tel. +49 62 91 64 400		
Typ DF23A4C1G2AM1V				
	II 1D2G/2GD EEx de IIB T6 T70°C IP66 IBExU 04 ATEX 1033 X		Supply 220...240V~ AC	
	II 1D2G/2GD c IIB T X IBExU 04 ATEX 1001 X		50...60Hz 3,5VA	
-25°C ≤ Ta ≤ +80°C / -20°C ≤ Ta ≤ +60°C		Δ p -0,08bar...+0,08bar		Contact 1mA 4V...2A 240V~
p (Process) -0,5bar...+5,0bar		Stück Nr. 1234567890 01/04		
Auftrag-Nr. 1234567890		A.-Nr. <input type="checkbox"/>		

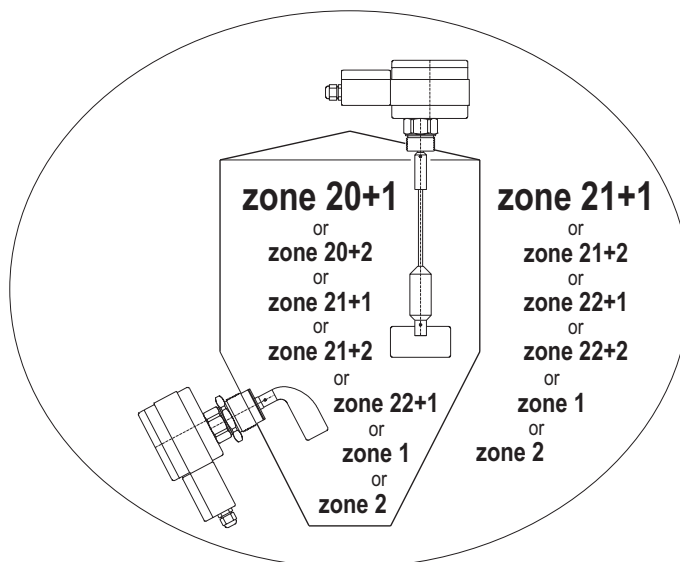

Ambient temperatures T_a if zone 0 is inside

The ambient temperature T_a defines the maximum operating temperature of the indicators. This can be the air and/or the temperature of the bulk goods inside the container.

MOLLET H.U.Breymann-Str.10 Füllstandtechnik GmbH D-74706 Osterburken Tel. +49 62 91 64 400		
Typ DF21A3C1G2AM1V		
$-25^{\circ}\text{C} \leq T_a \leq +80^{\circ}\text{C} / -20^{\circ}\text{C} \leq T_a \leq +60^{\circ}\text{C}$		Supply 220...240V~ AC
Δp -0,08bar...+0,08bar		50...60Hz 3,5VA
p (Process) -0,5bar...+5,0bar		Contact 1mA 4V...2A 240V~
Stück Nr. 1234567890 01/04		
Auftrag-Nr. 1234567890		

Type label for the zone separating element:

MOLLET H.U.Breymann-Str.10 Füllstandtechnik GmbH D-74706 Osterburken Tel. +49 62 91 64 400		
Typ DF-ZT		
		Stück Nr. 1234567890 - 01/04
$-25^{\circ}\text{C} \leq T_a \leq +80^{\circ}\text{C} / -20^{\circ}\text{C} \leq T_a \leq +70^{\circ}\text{C}$		A.- Nr. 1234567890
p (Process) -0,1bar...+5bar		

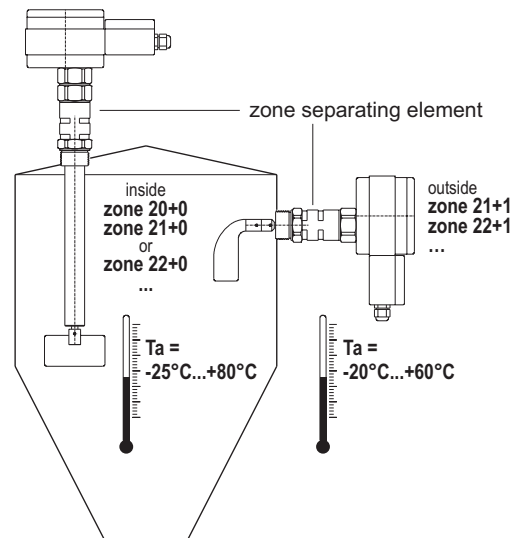

Maximum surface temperature T, TX if zone 0 is inside

The maximum surface temperature means the hottest point that can occur on the equipment in the case of a fault.

Note 1: The surface temperature T_X of the non-electrical part of the equipment (jib and measuring blade) is dependent on the bulk goods temperature resp. the ambient temperature. The non-electrical parts do not cause any hot surfaces.

MOLLET H.U.Breymann-Str.10 Füllstandtechnik GmbH D-74706 Osterburken Tel. +49 62 91 64 400		
Typ DF21A3C1G2AM1V		
$-25^{\circ}\text{C} \leq T_a \leq +80^{\circ}\text{C} / -20^{\circ}\text{C} \leq T_a \leq +60^{\circ}\text{C}$		Supply 220...240V~ AC
Δp -0,08bar...+0,08bar		50...60Hz 3,5VA
p (Process) -0,5bar...+5,0bar		Contact 1mA 4V...2A 240V~
Stück Nr. 1234567890 01/04		
Auftrag-Nr. 1234567890		

Type label for the zone separating element:

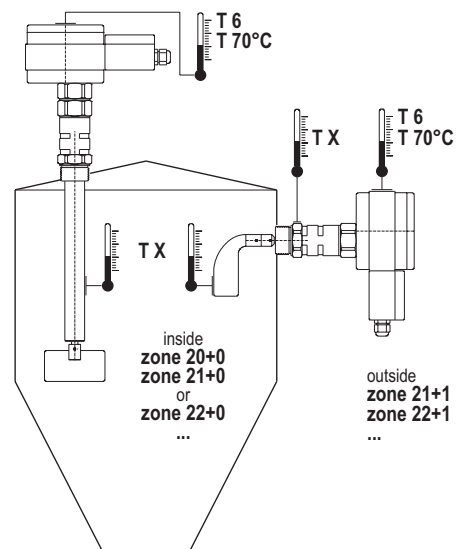

MOLLET H.U.Breymann-Str.10 Füllstandtechnik GmbH D-74706 Osterburken Tel. +49 62 91 64 400		
Typ DF-ZT		
		Stück Nr. 1234567890 - 01/04
$-25^{\circ}\text{C} \leq T_a \leq +80^{\circ}\text{C} / -20^{\circ}\text{C} \leq T_a \leq +70^{\circ}\text{C}$		A.- Nr. 1234567890
p (Process) -0,1bar...+5bar		





Note 2: The T in front of the X is not specified in the EN 13463-1 norm but makes it easier to understand the marking.

Ambient temperatures Ta

The ambient temperature T_a defines the maximum operating temperature of the indicators. This can be the air and/or the temperature of the bulk goods inside the container.

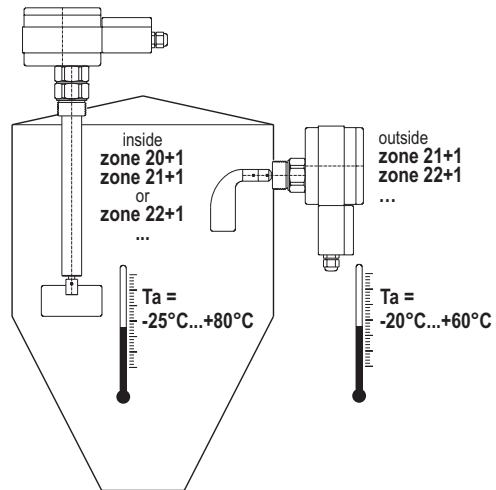
		H.U.Breyman-Str.10 D-74706 Osterburken Tel. +49 62 91 64 400		
Typ DF21A3C1G2AM1V				
 II 1D2G/2GD EEx de IIB T6 T70°C IP66 IBExU 04 ATEX 1033 X II 1D2G/2GD c IIB TX		Supply 220...240V~ AC 50...60Hz 3,5VA		
-25°C ≤ Ta ≤ +80°C / -20°C ≤ Ta ≤ +60°C Δp -0,08bar...+0,08bar		Contact 1mA 4V...2A 240V~		
p (Process) -0,5bar...+5,0bar				
Stück Nr. 1234567890 01/04 Auftrag-Nr. 1234567890				



		H.U.Breyman-Str.10 D-74706 Osterburken Tel. +49 62 91 64 400		
Typ DF21A4C1G2AM1V				
 II 1D2G/2GD EEx de IIB T6 T70°C IP66 IBExU 04 ATEX 1033 X II 1D2G/2GD c IIB TX		Supply 220...240V~ AC 50...60Hz 3,5VA		
-25°C ≤ Ta ≤ +80°C / -20°C ≤ Ta ≤ +60°C Δp -0,08bar...+0,08bar		Contact 1mA 4V...2A 240V~		
p (Process) -0,5bar...+5,0bar				
Stück Nr. 1234567890 01/04 Auftrag-Nr. 1234567890				

Type label for the temperature decoupling bell housing:

		H.U.Breyman-Str.10 D-74706 Osterburken Tel. +49 62 91 64 400		
Typ DF-E1				
 II 1D2G/2GD c IIB TX		Stück Nr. 1234567890 - 09/03 IBExU 04 ATEX 1001 X		
-25°C ≤ Ta ≤ +150°C / -20°C ≤ Ta ≤ +70°C		A.-Nr. 1234567890		

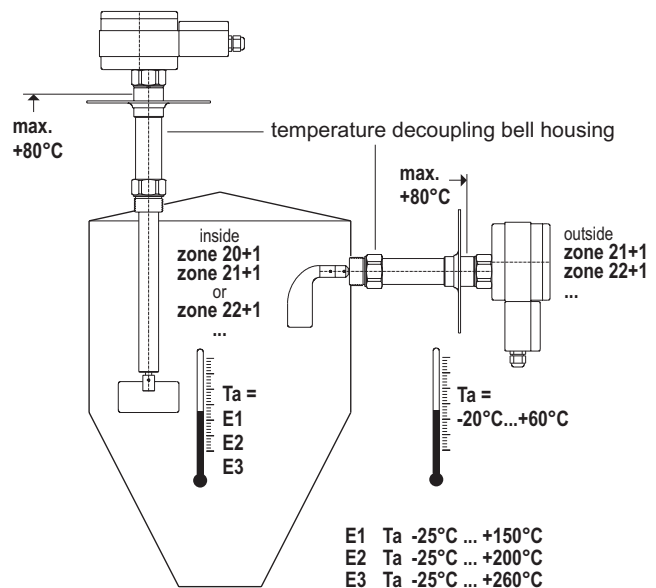

Maximum surface temperature T, TX

The maximum surface temperature means the hottest point that can occur on the equipment in the case of a fault.

Note 1: The surface temperature TX of the non-electrical part of the equipment (jib and measuring blade) is dependent on the bulk goods temperature resp. the ambient temperature. The non-electrical parts do not cause any hot surfaces.

MOLLET H.U.Brey mann-Str.10 Füllstandtechnik GmbH D-74706 Osterburken Tel. +49 62 91 64 400		CE 0032														
Typ DF21A3C1G2AM1V																
<table border="0"> <tr> <td>Ex II 1D2G/2GD EEx de IIB T6 T70°C IP66 IBE XU 04 ATEX 1033 X</td> <td>Supply 220...240V~ AC</td> </tr> <tr> <td>II 1D2G/2GD c IIB TX IBE XU 04 ATEX 1001 X</td> <td>50...60Hz 3,5VA</td> </tr> <tr> <td>-25°C ≤ Ta ≤ +80°C / -20°C ≤ Ta ≤ +60°C</td> <td>Contact 1mA 4V...2A 240V~</td> </tr> <tr> <td>Δp -0,08bar...+0,08bar</td> <td></td> </tr> <tr> <td>p (Process) -0,5bar...+5,0bar</td> <td></td> </tr> <tr> <td>Stück Nr. 1234567890 01/04</td> <td></td> </tr> <tr> <td>Auftrag-Nr. 1234567890</td> <td></td> </tr> </table>			Ex II 1D2G/2GD EEx de IIB T6 T70°C IP66 IBE XU 04 ATEX 1033 X	Supply 220...240V~ AC	II 1D2G/2GD c IIB TX IBE XU 04 ATEX 1001 X	50...60Hz 3,5VA	-25°C ≤ Ta ≤ +80°C / -20°C ≤ Ta ≤ +60°C	Contact 1mA 4V...2A 240V~	Δp -0,08bar...+0,08bar		p (Process) -0,5bar...+5,0bar		Stück Nr. 1234567890 01/04		Auftrag-Nr. 1234567890	
Ex II 1D2G/2GD EEx de IIB T6 T70°C IP66 IBE XU 04 ATEX 1033 X	Supply 220...240V~ AC															
II 1D2G/2GD c IIB TX IBE XU 04 ATEX 1001 X	50...60Hz 3,5VA															
-25°C ≤ Ta ≤ +80°C / -20°C ≤ Ta ≤ +60°C	Contact 1mA 4V...2A 240V~															
Δp -0,08bar...+0,08bar																
p (Process) -0,5bar...+5,0bar																
Stück Nr. 1234567890 01/04																
Auftrag-Nr. 1234567890																

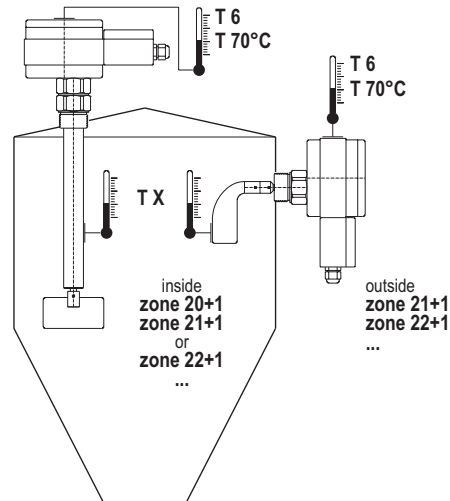

MOLLET H.U.Brey mann-Str.10 Füllstandtechnik GmbH D-74706 Osterburken Tel. +49 62 91 64 400		CE 0032														
Typ DF21A4C1G2AM1V																
<table border="0"> <tr> <td>Ex II 1D2G/2GD EEx de IIB T6 T70°C IP66 IBE XU 04 ATEX 1033 X</td> <td>Supply 220...240V~ AC</td> </tr> <tr> <td>II 1D2G/2GD c IIB TX IBE XU 04 ATEX 1001 X</td> <td>50...60Hz 3,5VA</td> </tr> <tr> <td>-25°C ≤ Ta ≤ +80°C / -20°C ≤ Ta ≤ +60°C</td> <td>Contact 1mA 4V...2A 240V~</td> </tr> <tr> <td>Δp -0,08bar...+0,08bar</td> <td></td> </tr> <tr> <td>p (Process) -0,5bar...+5,0bar</td> <td></td> </tr> <tr> <td>Stück Nr. 1234567890 01/04</td> <td></td> </tr> <tr> <td>Auftrag-Nr. 1234567890</td> <td></td> </tr> </table>			Ex II 1D2G/2GD EEx de IIB T6 T70°C IP66 IBE XU 04 ATEX 1033 X	Supply 220...240V~ AC	II 1D2G/2GD c IIB TX IBE XU 04 ATEX 1001 X	50...60Hz 3,5VA	-25°C ≤ Ta ≤ +80°C / -20°C ≤ Ta ≤ +60°C	Contact 1mA 4V...2A 240V~	Δp -0,08bar...+0,08bar		p (Process) -0,5bar...+5,0bar		Stück Nr. 1234567890 01/04		Auftrag-Nr. 1234567890	
Ex II 1D2G/2GD EEx de IIB T6 T70°C IP66 IBE XU 04 ATEX 1033 X	Supply 220...240V~ AC															
II 1D2G/2GD c IIB TX IBE XU 04 ATEX 1001 X	50...60Hz 3,5VA															
-25°C ≤ Ta ≤ +80°C / -20°C ≤ Ta ≤ +60°C	Contact 1mA 4V...2A 240V~															
Δp -0,08bar...+0,08bar																
p (Process) -0,5bar...+5,0bar																
Stück Nr. 1234567890 01/04																
Auftrag-Nr. 1234567890																

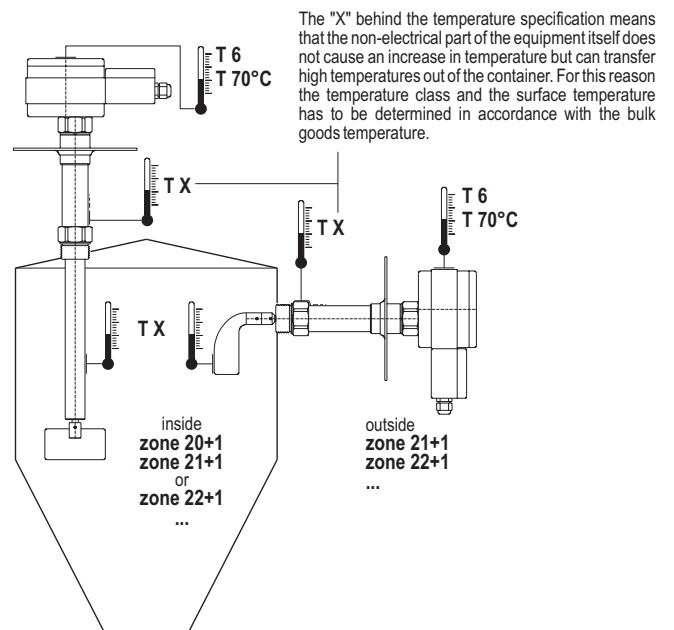

Type label for the temperature decoupling bell housing:

MOLLET H.U.Brey mann-Str.10 Füllstandtechnik GmbH D-74706 Osterburken Tel. +49 62 91 64 400		CE 0032						
Typ DF-E1								
<table border="0"> <tr> <td>Ex II 1D2G/2GD c IIB TX</td> <td>Stück Nr. 1234567890 - 09/03</td> </tr> <tr> <td>IBE XU 04 ATEX 1001 X</td> <td></td> </tr> <tr> <td>-25°C ≤ Ta ≤ +150°C / -20°C ≤ Ta ≤ +70°C</td> <td>A.- Nr. 1234567890</td> </tr> </table>			Ex II 1D2G/2GD c IIB TX	Stück Nr. 1234567890 - 09/03	IBE XU 04 ATEX 1001 X		-25°C ≤ Ta ≤ +150°C / -20°C ≤ Ta ≤ +70°C	A.- Nr. 1234567890
Ex II 1D2G/2GD c IIB TX	Stück Nr. 1234567890 - 09/03							
IBE XU 04 ATEX 1001 X								
-25°C ≤ Ta ≤ +150°C / -20°C ≤ Ta ≤ +70°C	A.- Nr. 1234567890							

Note 2: The T in front of the X is not specified in the EN 13463-1 norm but makes it easier to understand the marking.

Pressure, vacuum p, p (process)

High and low pressures in non-atmospheric conditions

The regulations, legislation and ordinances must be strictly observed when using rotary blade level indicators in containers with high and low pressures.

MOLLET GmbH Füllstandtechnik		H.U.Breymann-Str.10 D-74706 Osterburken Tel. +49 62 91 64 400		
Typ DF21A3C1G2AM1V				
II 1D2G/2GD EEx de IIB T6 T70°C IP66 IBExU 04 ATEX 1033 X II 1D2G/2GD c IIB T X		Supply 220...240V~ AC 50...60Hz 3,5VA		
-25°C ≤ Ta ≤ +80°C / -20°C ≤ Ta ≤ +60°C Δp -0,08bar...+0,08bar		Contact 1mA 4V...2A 240V~		
p (Process) -0,5bar...+5,0bar				
Stück Nr. 1234567890 01/04 Auftrag-Nr. 1234567890				

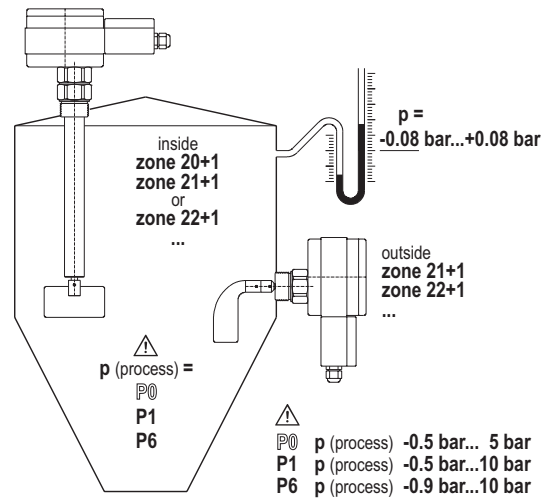

MOLLET GmbH Füllstandtechnik		H.U.Breymann-Str.10 D-74706 Osterburken Tel. +49 62 91 64 400		
Typ DF21A3C1G2AM1V				
II 1D2G/2GD EEx de IIB T6 T70°C IP66 IBExU 04 ATEX 1033 X II 1D2G/2GD c IIB T X		Supply 220...240V~ AC 50...60Hz 3,5VA		
-25°C ≤ Ta ≤ +80°C / -20°C ≤ Ta ≤ +60°C Δp -0,08bar...+0,08bar		Contact 1mA 4V...2A 240V~		
p (Process) -0,5bar...+5,0bar				
Stück Nr. 1234567890 01/04 Auftrag-Nr. 1234567890				

Type label for the pressure decoupling bell housing:

MOLLET GmbH Füllstandtechnik		H.U.Breymann-Str.10 D-74706 Osterburken Tel. +49 62 91 64 400		
Typ DF-P2				
II 1D2G/2GD c IIB T X		IBExU 04 ATEX 1001 X		
-25°C ≤ Ta ≤ +80°C / -20°C ≤ Ta ≤ +70°C p (Process) -0,1bar...+10bar		Stück Nr. 1234567890 - 09/03 A.-Nr. 1234567890		

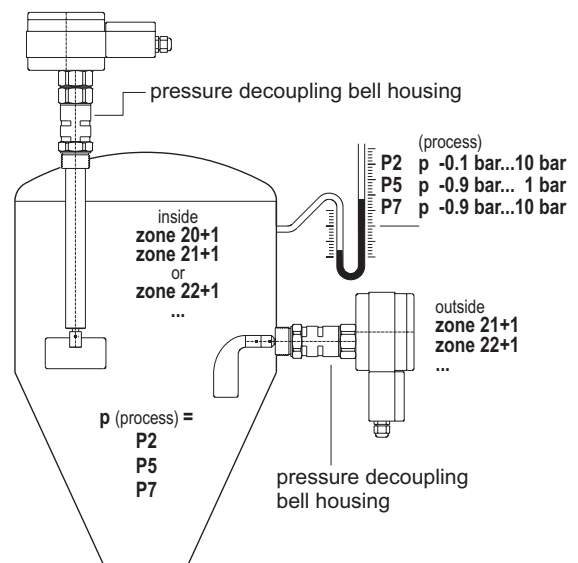

High and low pressure in the case of installation in the boundary between different zones

The dust density test in accordance with DIN EN 60529 (stipulated for ATEX equipment) with 20 mbar low pressure does not allow any difference in pressure between the container inner pressure, the pressure outside of the container and the housing inner pressure of the **rotary blade level indicator**.

As soon as a high or low pressure is given (for example due to pneumatic filling at a pressure up to approx. 40 mbar), then in this case these are **deviating atmospheric conditions** and the EC-type-examination certificate for such a rotary blade level indicator that has already been tested at only 20 mbar, is **not valid**.

IMPORTANT:

All MOLLET rotary blade level indicators **DF** have been tested by the "Notified Body" (testing agency) at 100 mbar.

As a consequence the **DF** rotary blade level indicator has been tested for a difference in pressure of 80 mbar (40 mbar plus adequate reserve) and can be used for containers and silos filled pneumatically.
> with **valid** EC-type-examination certificate.

Note:

These types of equipment are suitable for the following container pressures:

- 0.5 bar... 5 bar in the version **P0** (standard)
- 0.5 bar...10 bar in the version **P1**
- 0.9 bar...10 bar in the version **P6**



These pressures are no more under atmospheric conditions.

The definition according to the Directive 94/9/EC is only valid for atmospheric conditions. When used in non-atmospheric conditions the equipment is subject to the Ordinance on Safety and Health Protection and Operation of Equipment Requiring Monitoring and Organisation of Operational Work Protection (Operating Safety Ordinance [BetrSichV]) and is the responsibility of the operator.

Approval in this case is not valid.

High and low pressure in the case of installation of a pressure decoupling bell housing

Increasing high and/or low pressures in containers such as occur, for example, in the case of pressure vessels for high pressure conveyance (senders) or vessels in a vacuum conveying system are not affected by the Directive 94/9/EC.

No EC-type-examination certificates and/or EC-Declaration of conformity can be available for these operation conditions because there is no legal basis given for this in Germany.

IMPORTANT:

The EC-type-examination certificate **remains valid** in the case of the installation of a

pressure decoupling bell housing optional **P2**, **P5** or **P7**.

The electrical equipment (control head) is disconnected by means of the bell housing from the pressure and is within the atmospheric range.

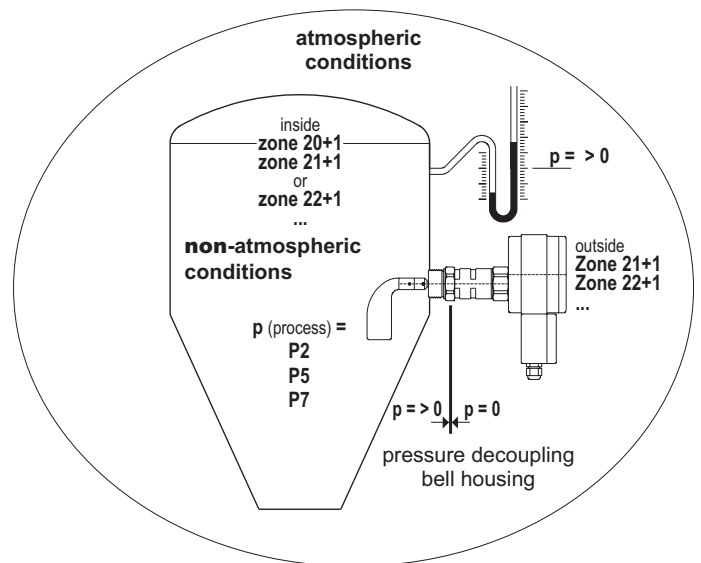



Special conditions and instructions for safe application

- ▶ The connection cable used must be designed for a temperature of min. +80 °C when using the level indicators for an ambient temperature > +60 °C.
- ▶ The level indicators may only be supplemented by such non-electrical components (jib and measuring blade) which are in accordance with the demands of the Directive 94/9/EC.
- ▶ The maximum difference in pressure at the shaft passage must not exceed 80 mbar and the working temperature on the shaft seal must not exceed +80 °C, when installing level indicators in the silo wall under deviating atmospheric conditions.
- ▶ The process connection, jib and measuring blade must be made of stainless steel in the case of combustible dusts with a minimum ignition energy under 3mJ or a minimum ignition temperature under +300 °C (BAM assessment).
- ▶ The plastic measuring blade TK 150 must not be installed.